

2 3003770

CHANGE ORDER



- Owner
- Architect
- Contractor
- O.P.M
- CX Agent
- Civil
- Landscape
- Geotech
- Structural
- MEP-FP
- FF&E
- Sustainability
- Acoustics
- Other
- Other

Project Name: **Stoughton Fire Station No. 1** CO No. **09**
 400 Prospect Street

Architect's Project No. **19-0796**

Owner: **Town of Stoughton** Architect: **DORE + WHITTIER**
 10 Pearl Street 260 Merrimac St, Bldg 7,
 Stoughton, MA 02072 Newburyport, MA 01950

To: **CTA Construction Managers** Issue Date **10/30/2024**
 400 Totten Pond Rd. Contract Date: **5/1/2023**
 Waltham, MA 02451

Attention: **Terry Vleux**

Change Order No. 09

See attached list of 11 Item(s) for a total of..... \$ 10,345.56

Not valid until signed by both the Owner and Architect.

Signature of the Contractor Indicates his agreement herewith, including any adjustment in the Contract Sum or Contract Time.

The original Contract Sum was.....	\$17,935,000.00
Net change by previously authorized Change Orders.....	\$771,516.83
The Contract Sum prior to this Change Order was.....	\$18,706,516.83
The Contract Sum will be INCREASED by this Change Order.....	\$10,345.56
The new Contract Sum Including this Change Order will be.....	\$18,716,862.39
The Contract Time will be changed by.....	*22 days
The Date of Substantial Completion as of the date of this Change Order therefore is:	*September 20, 2024

AUTHORIZED:

ARCHITECT:
DORE + WHITTIER
 260 Merrimac St, Bldg. 7
 Newburyport, MA 01950

OWNER:
Town of Stoughton
 10 Pearl Street
 Stoughton, MA 02072

CONTRACTOR:
CTA Construction Managers
 400 Totten Pond Rd.
 Waltham, MA 02451

BY:  **Donald M. Walter**
 Date: _____

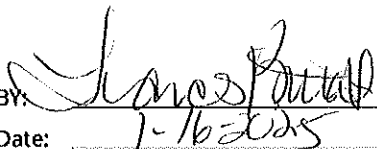
BY: 
 Date: 1-16-2025

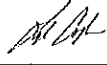
Name: * Lyle Coghlin 
 Title: Member
 Date: 11/11/24

Certification of Appropriation under M.G.L. c44, s31C:
 Adequate funding in an amount sufficient to cover the total cost of this
 Change Order is available

Name: _____
 Title: _____
 Date: _____

* CTA reserves its rights to additional time and direct and indirect costs associated with this change order. CTA does not waive its rights to an additional extension of time or to recover additional costs by signing this change order. The Awarding Authority, in executing this change order, agrees that CTA has properly reserved its rights for additional time and compensation.

CCD/PR/PCO Number	Description	Amount
PCO #62	Exterior HM Frames - Throat Depth	1,227.81
PCO #78	Sidewalk Repair - Coordination with Gas Company Issue?	1,135.42
PCO #80	Electrical - Connecting Building Letters wires	1,952.19
PCO #81	Electrical - Range Hood EF connection	459.34
PCO #82	Electrical - CO Detection wiring	370.03
PCO #83	Electrical - Add receptacle for alerting message board	446.31
PCO #84	Electrical - Relocate Boiler Shut-offs by AHJ	679.09
PCO #85	Electrical - SCBA Compressor Fuse Reducer & SCBA Washer power cord	966.56
PCO #86	Electrical - Ice Maker Cable	376.78
PCO #88	CCD-10 Sidewalk Added Area at front door (incl. new wheelbarrow - TBD)	1,283.17
PCO #89	Relocate VRF at Kitchen Ceiling	1,448.86
Change Order #09		TOTAL: 10,345.56

Copies of supporting documentation for each item listed above is attached following.



Construction Managers

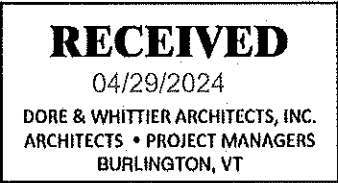

PCO #062

CTA Construction Managers
400 Totten Pond Road
Waltham, 02451
Phone: (781) 786-6600

Object: 2023-01 - Stoughton Fire Station No.01
400 Prospect Street
Stoughton, 02072

Prime Contract Potential Change Order #062: CE #097 - exterior hurricane frames- revise frame depth

TO:	Town of Stoughton 10 Pearl St Stoughton Massachusetts, 02072	FROM:	CTA Construction Managers, LLC 400 Totten Pond Road, 2nd Floor Waltham Massachusetts, 02451
PCO NUMBER/REVISION:	062 / 0	CONTRACT:	1 - Stoughton Fire Station No 1
REQUEST RECEIVED FROM:		CREATED BY:	Jo-Ann Darrigo (CTA Construction Managers, LLC)
STATUS:	Pending - In Review	CREATED DATE:	4/24 /2024
REFERENCE:		PRIME CONTRACT CHANGE ORDER:	None
FIELD CHANGE:	No		
LOCATION:		ACCOUNTING METHOD:	Amount Based
SCHEDULE IMPACT:		PAID IN FULL:	No
		TOTAL AMOUNT:	\$1,227.81

POTENTIAL CHANGE ORDER TITLE: CE #097 - exterior hurricane frames- revise frame depth

CHANGE REASON: Client Request

POTENTIAL CHANGE ORDER DESCRIPTION: (The Contract Is Changed As Follows)

CE #097 - exterior hurricane frames- revise frame, sidell, engineering
In PR 27- HM doors and frames were changed to 'Hurricane' rated
PCO45r changed the doors and later PCO52r included engineering costs to re- verify frames met Hurricane standard. All included in change event 85
.Frame premium is included in PCO 48 and is in dispute.

In THIS change event, the cost included revising the 6 3/4 frame to a 9 1/8 jamb depth. why? This PR was received after electrical conduit had been run and using a 6 3/4 frame would have put the conduit outside the frame as the frame would have had to move inboard so that the anchor hit the backup wall. This was confirmed thru engineering process.

*CTA reserves its rights to additional time and direct and indirect costs associated with this change order. CTA does not waive its rights to an additional extension of time or to recover additional costs by signing this change order. The Awarding Authority, in executing this change order, agrees that CTA has properly reserved its rights for additional time and compensation.

ATTACHMENTS:

PR 27 - Impact Openings & Hardware.pdf CO - PR 27 Adder - JD to 9.125 (003).pdf

#	Cost Code	Description	Type	Amount
1	08-100 - Doors	revise frame depth for exterior frames	CTA Sub	\$ 1,169.34
Subtotal:				\$1,169.34
CTA Direct: 10.00% Applies to CTA Direct.				\$ 0.00
CTA Sub: 5.00% Applies to CTA Sub .				\$ 58.47
Filed Sub: 5.00% Applies to Filed Sub Bidder .				\$ 0.00
CTA Bonds & Insurance: 0.00% Applies to Filed Sub Bidder , CTA Sub , and CTA Direct.				\$ 0.00
Grand Total:				\$1,227.81

**Contemplated Change Order #14
Exterior JD to 9 1/8"**

-1	Single Door #112B	Exterior from Electrical 112	90° RHR
1	Single Door #112B	Exterior from Electrical 112	90° RHR
-1	SGL F 14 4 634 3670 A60 WF 4HS LH (ASA; CHR; DPS; EMAHATNB 71-76 THRU 918; NO/SILENCER; RA/PA; Expansion Sheild 3/8 X 6" H,PW)		(673.40)
1	SGL F 14 4 918 3670 A60 WF 4HS LH (ASA; CHR; DPS; EMAHATNB 71-76 THRU 918; NO/SILENCER; RA/PA; Expansion Sheild 3/8 X 6" H,PW)		773.33
		Opening Total:	<u>99.93</u>
-1	Single Door #114B	Exterior from Mechanical 114	90° RHR
1	Single Door #114B	Exterior from Mechanical 114	90° RHR
-1	SGL F 14 4 634 3870 A60 WF 4HS LH (ASA; CHR; DPS; EMAHATNB 71-76 THRU 918; NO/SILENCER; RA/PA; Expansion Sheild 3/8 X 6" H,PW)		(673.40)
1	SGL F 14 4 918 3870 A60 WF 4HS LH (ASA; CHR; DPS; EMAHATNB 71-76 THRU 918; NO/SILENCER; RA/PA; Expansion Sheild 3/8 X 6" H,PW)		773.33
		Opening Total:	<u>99.93</u>
-1	Single Door #118B	Exterior from Water / Sprinkler 118	90° LHR
1	Single Door #118B	Exterior from Water / Sprinkler 118	90° LHR
-1	SGL F 14 4 634 3870 A60 WF 4HS RH (ASA; CHR; DPS; EMAHATNB 71-76 THRU 918; NO/SILENCER; RA/PA; Expansion Sheild 3/8 X 6" H,PW)		(673.40)
1	SGL F 14 4 918 3870 A60 WF 4HS RH (ASA; CHR; DPS; EMAHATNB 71-76 THRU 918; NO/SILENCER; RA/PA; Expansion Sheild 3/8 X 6" H,PW)		773.33
		Opening Total:	<u>99.93</u>
-1	Single Door #119	Exterior from Corridor 119B	90° RHR
1	Single Door #119	Exterior from Corridor 119B	90° RHR
-1	Opening 119		(1,355.76)
1	119		1,454.32
		Opening Total:	<u>98.59</u>
-1	Pair Doors #120B	Exterior from Ext Operations Storage & Site Maint 120	90/90° LHRA
1	Pair Doors #120B	Exterior from Ext Operations Storage & Site Maint 120	90/90° LHRA
-1	DBL F 14 4 634 6070 A60 WF 4HS LHRA (CHR; EMAHATNB 71-76 THRU 918; FB; NO/SILENCER; RA/PA-BOTH; Expansion Sheild 3/8 X 6" H,PW)		(1,065.35)
1	DBL F 14 4 918 6070 A60 WF 4HS LHRA (CHR; EMAHATNB 71-76 THRU 918; FB; NO/SILENCER; RA/PA-BOTH; Expansion Sheild 3/8 X 6" H,PW)		1,196.03
		Opening Total:	<u>130.68</u>

The products contained in this proposal are quoted with current factory lead times unless noted otherwise.

This proposal expires in 60 days.

**Contemplated Change Order #14
Exterior JD to 9 1/8"**

-1	Pair Doors #121B	Exterior from SCBA Compressor 121	90/90° RHRA	
1	Pair Doors #121B	Exterior from SCBA Compressor 121	90/90° RHRA	
-1	DBL F 14 4 634 6070 A60 WF 4HS RHRA (CHR; EMAHATNB 71-76 THRU 918; FB; NO/SILENCER; RA/PA-BOTH; Expansion Sheild 3/8 X 6" H,PW)			(1,065.35)
1	DBL F 14 4 918 6070 A60 WF 4HS RHRA (CHR; EMAHATNB 71-76 THRU 918; FB; NO/SILENCER; RA/PA-BOTH; Expansion Sheild 3/8 X 6" H,PW)			1,196.03
		Opening Total:		<u>130.68</u>
-1	Single Door #134K	Exterior from Apparatus Bay 134	90° LHR	
1	Single Door #134K	Exterior from Apparatus Bay 134	90° LHR	
-1	Opening 134K			(1,271.02)
1	134K			1,374.12
		Opening Total:		<u>103.10</u>
-1	Single Door #135A	Exterior from Maintenance Bay 135	90° LHR	
1	Single Door #135A	Exterior from Maintenance Bay 135	90° LHR	
-1	Opening 135A			(1,271.02)
1	135A			1,374.12
		Opening Total:		<u>103.10</u>
-1	Single Door #135B	Exterior from Maintenance Bay 135	90° LHR	
1	Single Door #135B	Exterior from Maintenance Bay 135	90° LHR	
-1	Opening 135B			(1,355.76)
1	135B			1,454.32
		Opening Total:		<u>98.56</u>
-1	Single Door #S2-1B	Exterior from Stair 2 S2-1	90° LHR	
1	Single Door #S2-1B	Exterior from Stair 2 S2-1	90° LHR	
-1	Opening S2-1B			(1,355.76)
1	S2-1B			1,454.32
		Opening Total:		<u>98.56</u>
-1	Single Door #226	Dining Room 226 to Deck	90° RHR	
1	Single Door #226	Dining Room 226 to Deck	90° RHR	
-1	Opening 226			(1,261.60)
1	226			1,367.91
		Opening Total:		<u>106.31</u>

The products contained in this proposal are quoted with current factory lead times unless noted otherwise.

This proposal expires in 60 days.

Contemplated Change Order #14
Exterior JD to 9 1/8"

Section Totals

081000 - Hollow Metal Doors and Frames	1,169.34
Pre-Tax Total:	<u>1,169.34</u>

Taxes

MA	MASSACHUSETTS SALES TAX	0.00
	Tax Total:	<u>0.00</u>
	Grand Total:	<u>1,169.34</u>

The products contained in this proposal are quoted with current factory lead times unless noted otherwise.

This proposal expires in 60 days.

PROPOSAL REQUEST

- | | | |
|--|-------------------------------------|---|
| <input checked="" type="checkbox"/> Owner | <input type="checkbox"/> Civil | <input type="checkbox"/> FF&E |
| <input checked="" type="checkbox"/> Architect | <input type="checkbox"/> Landscape | <input type="checkbox"/> Sustainability |
| <input checked="" type="checkbox"/> Contractor | <input type="checkbox"/> Geotech | <input type="checkbox"/> Acoustics |
| <input checked="" type="checkbox"/> O.P.M | <input type="checkbox"/> Structural | <input type="checkbox"/> Other |
| <input type="checkbox"/> CX Agent | <input type="checkbox"/> MEP-FP | <input type="checkbox"/> Other |



Project Name: **Stoughton Fire Station No. 1** PR No. **27**

Architect's Project No. **19-0796**

Owner: **Town of Stoughton** Architect: **DORE + WHITTIER**
10 Pearl Street
Stoughton, MA 02072 **212 Battery St,**
Burlington, VT 05401

To: **CTA Construction Managers** Issue Date **1/19/2024**
400 Totten Pond Rd, 2nd Floor Contract Date: **5/1/2023**
Waltham, MA 02451

Attention: **Jo-Ann Darrlgo** Subject: **Impact rated door openngs**
Terry Vleux

Please submit an **itemized quotation** for changes in the Contract Sum and/ or Time incidental to proposed modifications to the Contract documents described herein.

THIS IS NOT A CHANGE ORDER NOR A DIRECTION TO PROCEED WITH THE WORK DESCRIBED HEREIN.

Make the following revisions at exterior door openings 112B, 114B, 118B, 119, 120B, 121B, S2-1B, 135A, 135B, and 226:

All openings are required by the state building code to be rated for large missile impact to Wind Zone 2 requirements consistent with ASTM E1885 and E1996 or the Florida State Building Code. Door leaves, frame types, and applicable hardware shall be listed in a door assembly test that passes the ASTM E1886 / E1996 tests or the Florida State Building Code; or alternate products as allowed by the substitution process in ASTM E1996 and permitted by code. Applicable hardware includes, but is not limited to locking hardware, exit devices, hinges, door gasketing, astragal seals, door bottom seals, thresholds, and rain drip assemblies. The contractor shall submit door and hardware solutions that meet an approved assembly per ASTM testing or Florida State Building Code and document the nature of substitutions (where proposed) as being acceptable under code limitations. Provide written documentation or certification that all hardware proposed conforms with the building code requirements as requested previously in submittal review. Resubmit product data for doors and frames that are compliant with large missile impact testing requirements.

Revise the door construction to be polyurethane foamed-in-place fill. Delete the requirement for steel core reinforcing if not required by the manufacturer for large missile impact testing.

Revise the frame specification to eliminate the need for thermal breaks in the frame. Provide frame types that are compliant with large missile impact testing noted herein.

Issued by

DORE + WHITTIER
Glen Gollrad

Copy: File

Attachments: N/A



PCO #078

CTA Construction Managers
 400 Totten Pond Road
 Waltham, 02451
 Phone: (781) 786-6600

Project: 2023-01 - Stoughton Fire Station No.01
 400 Prospect Street
 Stoughton, 02072

Prime Contract Potential Change Order #078: CE #136 - sidewalk repair due to gas co repair

TO:	Town of Stoughton 10 Pearl St Stoughton Massachusetts, 02072	FROM:	CTA Construction Managers, LLC 400 Totten Pond Road, 2nd Floor Waltham Massachusetts, 02451
PCO NUMBER/REVISION:	078 / 0	CONTRACT:	1 - Stoughton Fire Station No 1
REQUEST RECEIVED FROM:		CREATED BY:	Jo-Ann Darrigo (CTA Construction Managers, LLC)
STATUS:	Pending - In Review	CREATED DATE:	8/23 /2024
REFERENCE:		PRIME CONTRACT CHANGE ORDER:	None
FIELD CHANGE:	No		
LOCATION:		ACCOUNTING METHOD:	Amount Based
SCHEDULE IMPACT:		PAID IN FULL:	No
		TOTAL AMOUNT:	\$1,135.42

POTENTIAL CHANGE ORDER TITLE: CE #136 - sidewalk repair due to gas co repair

CHANGE REASON: Client Request

POTENTIAL CHANGE ORDER DESCRIPTION: (The Contract Is Changed As Follows)

CE #136 - sidewalk repair
 Gas company installed gas line too high and sidewalk had to be torn out (by them) and then replaced by CTA

*CTA reserves its rights to additional time and direct and indirect costs associated with this change order. CTA does not waive its rights to an additional extension of time or to recover additional costs by signing this change order. The Awarding Authority, in executing this change order, agrees that CTA has properly reserved its rights for additional time and compensation.

ATTACHMENTS:

JNB Construction - w.e. 7.20.24.pdf Pro Tool & Supply - 5347766 sidewalk.pdf

#	Cost Code	Description	Type	Amount
1	01-000 - Purpose	re-pour sidewalk-material	CTA Direct	\$ 307.66
2	01-000 - Purpose	re-pour sidewalk- labor	CTA Direct	\$ 724.64
Subtotal:				\$1,032.20
CTA Direct: 10.00% Applies to CTA Direct.				\$ 103.22
CTA Sub: 5.00% Applies to CTA Sub .				\$ 0.00
Filed Sub: 5.00% Applies to Filed Sub Bidder .				\$ 0.00
CTA Bonds & Insurance: 0.00% Applies to Filed Sub Bidder , CTA Sub , and CTA Direct.				\$ 0.00
Grand Total:				\$1,135.42

INVOICE

Pro Tool and Supply Inc

Branch: 000 Waltham
 126 CALVARY ST
 P O BOX 541586
 Waltham, MA 02454

781-899-0790

Bill To:
 CTA CONSTRUCTION COMPANY INC.
 400 TOTTEN POND ROAD
 2ND FLOOR
 WALTHAM, MA 02451-1552

Ship To:
 STOUGHTON FIRE
 400 PROSPECT STREET
 STOUGHTON, MA

Attn: ACCOUNTS PAYABLE

Ordered By: Mr. LEO GALLANT

Customer ID: 10944

INVOICE	
5347766	
Invoice Date	Page
7/31/2024 11:34:18	1 of 2
ORDER NUMBER	
1316102	

PO Number	Term Description	Net Due Date	Disc Due Date	Discount Amount
STOUGHTON FIRE	Net 30	8/30/2024	8/30/2024	0.00

Order Date	Pick Ticket No	Primary Salesrep Name	Taker
7/9/2024 09:11:00	3382255	Anthony Fierimonte	MSPINALE

Quantities			Item ID	UOM	Unit Price	Extended Price
Ordered	Shipped	UOM Unit Size	Item Description	Unit Size		

Delivery Instructions: LEO 617-212-3497 /// DEL WED JULY 10TH

Carrier: O/T

Tracking #:

6	6	EA	RAMBOARD-38 FLOOR PROTECTION 38"x100FT	EA	69.9000	419.40
		1.0		1.0000		
6	6	EA	SHU104950 2"BLUE TAPE CP011 ECON 24CS old#104848 COLONIAL	EA	7.9695	47.82
		1.0		1.0000		
Ordered As: BT						
20	20	EA	AB22021 CUTOFF WHEEL 4-1/2x.045x7/8 STEEL (50)	EA	3.5000	70.00
		1.0		1.0000		
15	15	EA	CEMENT80 80LB CEMENT(GRAVEL) MIX QKCRETE 1007-00 5000 42 BAGS TO A PALLET	EA	13.9900	209.85
		1.0		1.0000		
1	1	EA	EW1899723 26:1 10OZ CAULK GUN HD	EA	40.7500	40.75
		1.0	EW1899723	1.0000		
6	6	EA	NS PLCONCRETE PL CONCRETE 10 OZ	EA	16.2857	97.71
		1.0		1.0000		

ORIGINAL

INVOICE

Pro Tool and Supply Inc

Branch: 000 Waltham
 126 CALVARY ST
 P O BOX 541586
 Waltham, MA 02454

781-899-0790

INVOICE	
5347766	
Invoice Date	Page
7/31/2024 11:34:18	2 of 2
ORDER NUMBER	
1316102	

<i>Quantities</i>					<i>Item ID</i>	<i>Pricing UOM</i>	<i>Unit Price</i>	<i>Extended Price</i>
<i>Ordered</i>	<i>Shipped</i>	<i>UOM</i>	<i>Unit Size</i>	<i>Disp.</i>				

Total Lines: 6

SUB-TOTAL: 885.53
MASS STATE: 55.36
AMOUNT DUE: 940.89

Ok JD 8/23 - 8050

JNB CONSTRUCTION INC

stoughton see sep invoice for concord

Labor for Week Ending: 7 20 2024

	Regular	Overtime	Total	Rate	Wages	
kelly	7		7	\$40.00	\$280.00	
nathan	8		8	\$40.00	\$320.00	
penzo	16		16	\$64.70	\$1,035.20	8hrs is sidewalk repair
suarez				\$64.70		

TOTAL 31 0 31 \$1,635.20

Payroll taxes, etc 40% 654.08

TOTAL: \$2,289.28

OK JD 8/23

POSTED - 25806 - BH

COST CODE - *NEED* 16 hrs 8058; balance to 8040

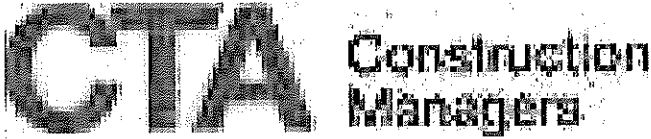

PCO #080 ✓

CTA Construction Managers
 400 Totten Pond Road
 Waltham, 02451
 Phone: (781) 786-6600

Project: 2023-01 - Stoughton Fire Station No.01
 400 Prospect Street
 Stoughton, 02072

DRAFT

Prime Contract Potential Change Order #080: CE #145 -rfi 142 - wire bldg sign

TO:	Town of Stoughton 10 Pearl St Stoughton Massachusetts, 02072	FROM:	CTA Construction Managers, LLC 400 Totten Pond Road, 2nd Floor Waltham Massachusetts, 02451
PCO NUMBER/REVISION:	080 / 0	CONTRACT:	1 - Stoughton Fire Station No 1
REQUEST RECEIVED FROM:		CREATED BY:	Jo-Ann Darrigo (CTA Construction Managers, LLC)
STATUS:	Draft	CREATED DATE:	9/10 /2024
REFERENCE:		PRIME CONTRACT CHANGE ORDER:	None
FIELD CHANGE:	No		
LOCATION:		ACCOUNTING METHOD:	Amount Based
SCHEDULE IMPACT:		PAID IN FULL:	No
		TOTAL AMOUNT:	\$1,952.19 ✓

POTENTIAL CHANGE ORDER TITLE: CE #145 -rfi 142 - wire bldg sign

CHANGE REASON: Client Request

POTENTIAL CHANGE ORDER DESCRIPTION: (The Contract Is Changed As Follows)
 CE #144 - rfi 145 wire bldg sign

*CTA reserves its rights to additional time and direct and indirect costs associated with this change order. CTA does not waive its rights to an additional extension of time or to recover additional costs by signing this change order. The Awarding Authority, in executing this change order, agrees that CTA has properly reserved its rights for additional time and compensation.

ATTACHMENTS:

142 bldg sign power.pdf 2316-126 T&M.pdf

#	Cost Code	Description	Type	Amount
1	16-100 - Electrical	wire bldg sign	Filed Sub Bidder	\$ 1,859.23
Subtotal:				\$1,859.23
CTA Direct: 10.00% Applies to CTA Direct.				\$ 0.00
CTA Sub: 5.00% Applies to CTA Sub .				\$ 0.00
Filed Sub: 5.00% Applies to Filed Sub Bidder .				\$ 92.96
CTA Bonds & Insurance: 0.00% Applies to Filed Sub Bidder , CTA Sub , and CTA Direct.				\$ 0.00
Grand Total:				\$1,952.19

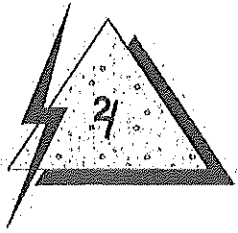

September 6, 2024

CTA Construction Managers
400 Totten Pond Road
2nd Floor
Waltham, MA 02451
Attn: Terry Vieux tvieux@ctaconstruction.com
Paula Martin pmartin@ctaconstruction.com
Tel: 781-786-6629

RE: Stoughton Fire Station 400 Prospect Steet Stoughton, MA 02072 Change Order Proposal: #2316-126

To Whom it May Concern,

COP #2316-126– T&M in the amount of **\$1,859.23**.

DESCRIPTION	QTY	UNIT COST	UNIT EXT	LABOR HOURS	LABOR EXT
T & M on 8/14/2024	1		\$0.00	9	9
T & M on 8/15/2024	1		\$0.00	3	3
Coordination	1		\$0.00	5	5
Subtotal			\$0.00		17.00
LABOR					
Electrician	17.00	\$76.48	\$1,300.16		
30% Insurance and Tax			\$390.05		
Total Labor			\$1,690.21		
Total Material			\$0.00		
Subtotal Labor and Material			\$1,690.21		
10% Overhead and Profit			\$169.02		
TOTAL CHANGE ORDER AMOUNT			\$1,859.23		

If you have any questions or concerns, please call our office.

Thank you,

Brad Kelloway
Project Manager

J
U
P
I
T
E
R
E
L
E
C
T
R
I
C
I
N
C.

JUPITER ELECTRIC, INC.
 142 B LAFAYETTE ROAD
 SALISBURY, MA 01952

TIME AND MATERIAL

978-499-7776 Fax: 978-499-3838

TO Bob Rice (Pomfret)

Number

PHONE	DATE 8/15/24
JOB NAME/LOCATION Stoughton Fire	
JOB NUMBER	JOB PHONE
EXISTING CONTRACT NO.	DATE OF EXISTING CONTRACT

We hereby agree to make the change(s) specified below:

^{From} VWincen Building sign to (2) controllers powered by Jupiter

8/14/24 Dayon 7-2 7 hrs
 Steve 12-2 2 hrs

8/15/24 Dayon 6-9 3 hrs

Total 12 hrs

CTA Construction Co., Inc.
 Time & Material Verifications

Verified: [Signature]
 Date: 8-15-24

Signature above is for verification of time and materials quantities only. Signature above does not guarantee payment.

NOTE: This Time and Material becomes part of and in conformance with the existing contract.

WE AGREE hereby to make the change(s) specified above at this price ➡		\$	
DATE	PREVIOUS CONTRACT AMOUNT	\$	
AUTHORIZED SIGNATURE (CONTRACTOR)	REVISED CONTRACT TOTAL	\$	

ACCEPTED — The above prices and specifications of this Time and Material Form are satisfactory and are hereby accepted. All work to be performed under same terms and conditions as specified in original contract unless otherwise stipulated.

Date of acceptance 8-15-24
 Signature [Signature]
 (OWNER)



PCO #081

CTA Construction Managers
 400 Totten Pond Road
 Waltham, 02451
 Phone: (781) 786-6600

Project: 2023-01 - Stoughton Fire Station No.01
 400 Prospect Street
 Stoughton, 02072

Prime Contract Potential Change Order #081: CE #144 - rfi 140- hood interconnect by electrician

TO:	Town of Stoughton 10 Pearl St Stoughton Massachusetts, 02072	FROM:	CTA Construction Managers, LLC 400 Totten Pond Road, 2nd Floor Waltham Massachusetts, 02451
PCO NUMBER/REVISION:	081 / 0	CONTRACT:	1 - Stoughton Fire Station No 1
REQUEST RECEIVED FROM:		CREATED BY:	Jo-Ann Darrigo (CTA Construction Managers, LLC)
STATUS:	Pending - In Review	CREATED DATE:	9/10 /2024
REFERENCE:		PRIME CONTRACT CHANGE ORDER:	None
FIELD CHANGE:	No		
LOCATION:		ACCOUNTING METHOD:	Amount Based
SCHEDULE IMPACT:		PAID IN FULL:	No
		TOTAL AMOUNT:	\$918.68

POTENTIAL CHANGE ORDER TITLE: CE #144 - rfi 140- hood interconnect by electrician

CHANGE REASON: Client Request

POTENTIAL CHANGE ORDER DESCRIPTION: *(The Contract Is Changed As Follows)*

CE #144 - rfi 140- hood interconnect by electrician
 interconnect between hood and fan is not on electrical drwgs

*CTA reserves its rights to additional time and direct and indirect costs associated with this change order. CTA does not waive its rights to an additional extension of time or to recover additional costs by signing this change order. The Awarding Authority, in executing this change order, agrees that CTA has properly reserved its rights for additional time and compensation.

ATTACHMENTS:

2316-126 T&M.pdf 140 range hood.pdf

#	Cost Code	Description	Type	Amount
1	16-100 - Electrical	interconnect	Filed Sub Bidder	\$ 874.93
Subtotal:				\$874.93
CTA Direct: 10.00% Applies to CTA Direct.				\$ 0.00
CTA Sub: 5.00% Applies to CTA Sub .				\$ 0.00
Filed Sub: 5.00% Applies to Filed Sub Bidder .				\$ 43.75
CTA Bonds & Insurance: 0.00% Applies to Filed Sub Bidder , CTA Sub , and CTA Direct.				\$ 0.00
Grand Total:				\$918.68

RECEIVED

08/05/2024

Dore + Whittler Architects, Inc.
Architects • Project Managers
Burlington, VT

REQUEST FOR INTERPRETATION FORM

STOUGHTON FIRE STATION - #19-0796

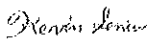
TO: Dore & Whittler Architects Inc. 260 Merrimac St., Bldg.7 Newburyport, MA 01950	FROM: CTA	RFI #: 140
Attn: Kevin Seniw	Reply Requested by: 08/05/2024	Issue Date: 8/1
RFI DESCRIPTION (Indicate origin of RFI, and summarize the question or type of information required): Electrician says there need to be an interconnect wire between RH and KE...and there isn't. please advise. see also rfi 92		
REFERENCES (List relevant Drawings or Specification sections and paragraphs):		
SENDER'S RECOMMENDATION (All RFIs must include a contractor's recommended solution to each condition, including a statement of cost or schedule of impact if applicable. The contractor may be back-charged by the Town of Stoughton for designer's review time for any RFI submitted without a sender's recommended solution or where response is evident in Drawings.)		
DESIGNER'S RESPONSE: Refer to engineer's response on following page.		
BY:  <small>Kevin Seniw Contact Info: kseniw@doreandwhittler.co Tel: 802.244.0000</small>	DATE:	COPIES TO:

RECEIVED
FROM CONSULTANT
08/06/2024
Dore + Whittier Architects, Inc.
Architects • Project Managers
Burlington, VT

REQUEST FOR INFORMATION - RFI

M#89998
J#894 109 01.00

DATE: August 6, 2024

TO: Kevin Senlw
Dore + Whittier

FROM: Jacob Duarte



DEPT: Electrical

PROJECT: Stoughton Fire Station No. 1
Stoughton, MA

SUBJECT: RFI #140: Interconnect Wiring for Range Hood and KE; See Also RFI #092

Question:

Electrician says there need to be an interconnect wire between RH and KE...and there isn't. please advise.

Response:

Per the instruction manual, when the system is provided with an external fan, there should have been a 50 foot, 4 wire plug and play orange cable provided for connection between the rooftop exhaust fan and range hood. If this was not provided, then the HVAC Contractor should reach out to the Manufacturer and have this provided. Refer to snippet below from the instruction manual.

External Fan – Fan by Others

If configured for an external fan by others, there will be a 50 ft. 4-wire plug and play cable with an **orange** label. Connect this to the orange harness in the hood, run it through a two inch knockout out of the controls j-box and out to the fan. Signals for each wire are shown:

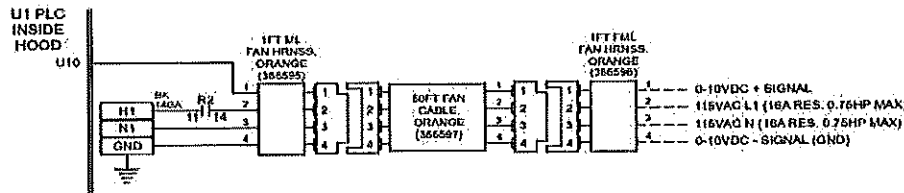

JD:kc

Enc.

Cc: Heather Gratton, Dore + Whittier
Glen Gollrad, Dore + Whittier



Construction
Managers

CTA Construction Managers
400 Totten Pond Road
Waltham, 02451
P: (781) 786-6600

RECEIVED

Project: 2023-01 Stoughton Fire Station No.01
400 Prospect Street
Stoughton, 02072

8/1/24

GGD Consulting Engineers, Inc.

RFI #140: interconnect wiring for range hood and KE; see also rfi 92

Status	Open		
To	Kevin Seniw (Dore & Whittier Architects Inc.) Glen Gollrad (Dore & Whittier Architects Inc.) GGD (GGD/ MEP/FP)	From	Jo-Ann Darrigo (CTA Construction Managers, LLC)
Date Initiated	Aug 1, 2024	Due Date	Aug 5, 2024
Location		Project Stage	
Cost Impact		Schedule Impact	
Spec Section		Cost Code	
Drawing Number		Reference	
Linked Drawings			
Received From	Steve Burke (Jupiter Electric Inc.)		
Copies To	Lyle Coghlin (CTA Construction Managers, LLC), Jo-Ann Darrigo (CTA Construction Managers, LLC), Bob Rice (Pomroy & Associates)		

Activity

Question

Question from Jo-Ann Darrigo CTA Construction Managers, LLC on Thursday, Aug 1, 2024 at 04:43 PM EDT
Electrician says there need to be an interconnect wire between RH and KE...and there isn't. please advise

Attachments

140 range hood.pdf

Awaiting an Official Response

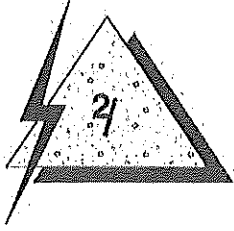

September 6, 2024

CTA Construction Managers
400 Totten Pond Road
2nd Floor
Waltham, MA 02451
Attn: Terry Vieux tvieux@ctaconstruction.com
Paula Martin pmartin@ctaconstruction.com
Tel: 781-786-6629

RE: **Stoughton Fire Station 400 Prospect Steet Stoughton, MA 02072 Change Order Proposal: #2316-124**

To Whom it May Concern,

COP #2316-124– T&M in the amount of \$874.93.

DESCRIPTION	QTY	UNIT COST	UNIT EXT	LABOR HOURS	LABOR EXT
T & M on 8/28/2024	1		\$0.00	6	6
Coordination	1		\$0.00	2	2
Subtotal			\$0.00		8.00
LABOR					
Electrician	8.00	\$76.48	\$611.84		
30% Insurance and Tax			\$183.55		
Total Labor			\$795.39		
Total Material			\$0.00		
Subtotal Labor and Material			\$795.39		
10% Overhead and Profit			\$79.54		
TOTAL CHANGE ORDER AMOUNT			\$874.93		

If you have any questions or concerns, please call our office.

Thank you,

Brad Kelloway
Project Manager

C
T
A
C
O
N
S
T
R
U
C
T
I
O
N
S

JUPITER ELECTRIC, INC.
 142 B LAFAYETTE ROAD
 SALISBURY, MA 01952

TIME AND MATERIAL

978-499-7776 Fax: 978-499-3838

TO Bob Rice (PanRay)

Number

PHONE	DATE
JOB NAME/LOCATION	
JOB NUMBER	JOB PHONE
EXISTING CONTRACT NO.	DATE OF EXISTING CONTRACT

We hereby agree to make the change(s) specified below:

- Fish into connect wires up to 2 kitchen exhaust fans from their respective hoods & make connections
 - install 2 GFCI receptacles under cabinet for
 (2) Ansul control boxes

EF connection work also carried in PCO #87 - where this exact same slip was included as well. D+W will delete the reference to it there, and keep it included here where it belongs as back-up

Labor: Steve Burke 7:30 - 1:30 6 hrs

NOTE: This Time and Material becomes part of and in conformance with the existing contract.

WE AGREE hereby to make the change(s) specified above at this price \$

DATE

PREVIOUS CONTRACT AMOUNT \$

AUTHORIZED SIGNATURE (CONTRACTOR)

REVISED CONTRACT TOTAL \$

ACCEPTED - The above prices and specifications of this Time and Material Form are satisfactory and are hereby accepted. All work to be performed under same terms and conditions as specified in original contract unless otherwise stipulated.

Date of acceptance

8-28-24

Signature



(OWNER)

GGD Consulting Engineers, Inc.

M#91138
J#894 109 01.00

DATE: October 31, 2024

MEMO

TO: Kevin Seniw
Dore + Whittier

FROM: Jacob Duarte

David M. Pereira, P.E., Principal





DEPT: Electrical

PROJECT: Stoughton Fire Station No. 1
Stoughton, MA

SUBJECT: PCO #082: CE #147-RFI 141-Power To App Bay CO Detection

Please be advised as follows:

We have reviewed the Jupiter Electric, Inc. portion of Proposed Change Order No. 082 in the amount of \$352.41 for costs associated with RFI #141: Power To App Bay CO Detection. We find the amount to be fair and reasonable and recommend your approval.

If you have any questions regarding this information, please contact our office at your earliest convenience.

JD:md

Enc.

Cc: Glen Gollrad, Dore + Whittier



**Construction
Managers**

PCO #082

CTA Construction Managers
400 Totten Pond Road
Waltham, 02451
Phone: (781) 786-6600



Project: 2023-01 - Stoughton Fire Station No.01
400 Prospect Street
Stoughton, 02072

Prime Contract Potential Change Order #082: CE #147 - rfi 141- Power to App bay CO detection

TO:	Town of Stoughton 10 Pearl St Stoughton Massachusetts, 02072	FROM:	CTA Construction Managers, LLC 400 Totten Pond Road, 2nd Floor Waltham Massachusetts, 02451
PCO NUMBER/REVISION:	082 / 0	CONTRACT:	1 - Stoughton Fire Station No 1
REQUEST RECEIVED FROM:		CREATED BY:	Jo-Ann Darrigo (CTA Construction Managers, LLC)
STATUS:	Pending - In Review	CREATED DATE:	9/10 /2024
REFERENCE:		PRIME CONTRACT CHANGE ORDER:	None
FIELD CHANGE:	No		
LOCATION:		ACCOUNTING METHOD:	Amount Based
SCHEDULE IMPACT:		PAID IN FULL:	No
		TOTAL AMOUNT:	\$370.03

POTENTIAL CHANGE ORDER TITLE: CE #147 - rfi 141- Power to App bay CO detection

CHANGE REASON: Allowance

POTENTIAL CHANGE ORDER DESCRIPTION: *(The Contract Is Changed As Follows)*
CE #147 - rfi 141- Power to App bay CO detection
rfi 141- Power to App bay CO detection

**NOTE: D+W ADDED ALL
PERTINENT BACK-UP REQUIRED
TO REVIEW PCO IN ITS ENTIRETY**

*CTA reserves its rights to additional time and direct and indirect costs associated with this change order. CTA does not waive its rights to an additional extension of time or to recover additional costs by signing this change order. The Awarding Authority, in executing this change order, agrees that CTA has properly reserved its rights for additional time and compensation.

ATTACHMENTS:

2316-125 T&M.pdf _rfi 141 gas detection power with CAM back up.pdf

#	Cost Code	Description	Type	Amount
1	16-100 - Electrical	--bring feed to CO detection	Filed Sub Bidder	\$ 352.41
Subtotal:				\$352.41
CTA Direct: 10.00% Applies to CTA Direct.				\$ 0.00
CTA Sub: 5.00% Applies to CTA Sub ,				\$ 0.00
Filed Sub: 5.00% Applies to Filed Sub Bidder ,				\$ 17.62
CTA Bonds & Insurance: 0.00% Applies to Filed Sub Bidder , CTA Sub , and CTA Direct.				\$ 0.00
Grand Total:				\$370.03

RECEIVED

08/06/2024

Dore + Whittier Architects, Inc.
Architects • Project Managers
Burlington, VT

REQUEST FOR INTERPRETATION FORM

STOUGHTON FIRE STATION - #19-0796

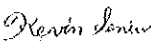
TO: Dore & Whittier Architects Inc. 260 Merrimac St., Bldg.7 Newburyport, MA 01950	FROM: CTA	RFI #: 141
Attn: Kevin Seniw	Reply Requested by: 08/09/2024	Issue Date: 5/6/24
RFI DESCRIPTION (indicate origin of RFI, and summarize the question or type of information required): see attached CAM rfi who provides electrical connection for Gas detection? what circuit and in what panel?		
REFERENCES (List relevant Drawings or Specification sections and paragraphs):		
SENDER'S RECOMMENDATION (All RFIs must include a contractor's recommended solution to each condition, including a statement of cost or schedule of impact if applicable. The contractor may be back-charged by the Town of Stoughton for designer's review time for any RFI submitted without a sender's recommended solution or where response is evident in Drawings.)		
DESIGNER'S RESPONSE: Refer to attached sheet from Engineer for response.		
BY:  Kevin Seniw	DATE:	COPIES TO:
<small>Contact Info: kseniw@doreandwhittier.com Date: 2024.08.13</small>		

RECEIVED

FROM CONSULTANT

08/13/2024

Dore + Whittier Architects, Inc.
Architects • Project Managers
Burlington, VT

GGD Consulting Engineers, Inc.

REQUEST FOR INFORMATION - RFI

M#90092
J#894 109 01.00

DATE: August 12, 2024

TO: Kevin Senlw
Dore + Whittier

FROM: Jacob Duarte

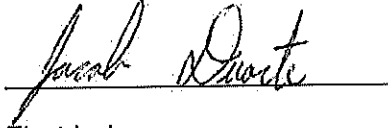

DEPT: Electrical

PROJECT: Stoughton Fire Station No. 1
Stoughton, MA

SUBJECT: RFI #141: Power Wiring for Gas Detection System

Question:

The electrician has informed CAM the power to the gas detection control system panel located on Drawing M1.10 is not in their scope of work. Typically, this power is provided by the electrician on site. Please clarify who is providing power to this panel.

Response:

Contractor to confirm Manufacturer has provided required step down transformer. Electrical Contractor is to provide 120V connection from local receptacle circuit to Manufacturer provided step down transformer and ATC to wire out to each gas detector.

JD:kc

Enc.

Cc: Heather Gratton, Dore + Whittier
Glen Gollrad, Dore + Whittier



Construction Managers

CTA Construction Managers
400 Totten Pond Road
Waltham, 02451
P: (781) 786-6600



Project: 2023-01 Stoughton Fire Station No.01
400 Prospect Street
Stoughton, 02072

RFI #141: Power wiring for gas detection system

Status Open

To Kevin Seniw (Dore & Whittler Architects Inc.)
Glen Gollrad (Dore & Whittler Architects Inc.)
GGD (GGD/ MEP/FP)

From Jo-Ann Darrigo (CTA Construction Managers, LLC)

Date Initiated Aug 6, 2024 **Due Date** Aug 9, 2024

Location **Project Stage**

Cost Impact **Schedule Impact**

Spec Section **Cost Code**

Drawing Number **Reference**

Linked Drawings

Received From Dennis Lutskiy (CAM HVAC & Construction Inc.)

Copies To Lyle Coghlin (CTA Construction Managers, LLC),
Jo-Ann Darrigo (CTA Construction Managers, LLC),
Bob Rice (Pomroy & Associates)

Activity

Question

Question from Jo-Ann Darrigo CTA Construction Managers, LLC on Tuesday, Aug 6, 2024 at 11:50 AM EDT
see CAM rfi attached, on who is providing power for CO detection

Attachments

rfi 141 gas detection power with CAM back up.pdf

Awaiting an Official Response

116 Lydia Ann Road
Smithfield, RI 02917

TITLE: Gas Detection Power Wiring
PROJECT: Stoughton Fire Station
TO: Attn: Terry Vieux
CTA Construction Company

DATE: 8/5/2024

JOB: 2524

STARTED: 8/5/2024

COMPLETED:

REQUIRED: 8/12/2024

QUESTION:

The electrician has informed CAM the power to the gas detection control system panel located on drawing M1.10 is not in their scope of work. Typically, this power is provided by the electrician on site. Please clarify who is providing power to this panel.

Requested By: CAM H.V.A.C. & Construction, Inc.

Date: 8/5/2024

Signed: _____
Dennis Lutskiy

VEHICLE EXH.
SYSTEM CONTROL
PANEL

TO MAIN
SERVICE
PANEL

TO EF-3

TO EF-4

SFTMPRO-301

SSRMPRO-662

SSRMPRO-662

SSRMPRO-662

GAS DETECTION CONTROL SYSTEM (INTER POLYGRAPH OR EQUAL)
BY ATC. UPON A RISE OF CONCOZ LEVELS THE ASSOCIATED EXHAUST
FAN SHALL OPERATE AND NORMALLY CLOSED M.D. SHALL OPEN



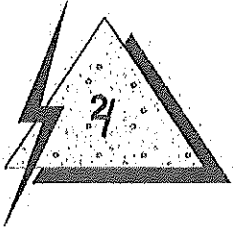

September 6, 2024

CTA Construction Managers
400 Totten Pond Road
2nd Floor
Waltham, MA 02451
Attn: Terry Vieux tvieux@ctaconstruction.com
Paula Martin pmartin@ctaconstruction.com
Tel: 781-786-6629

RE: Stoughton Fire Station 400 Prospect Steet Stoughton, MA 02072 Change Order Proposal: #2316-125

To Whom it May Concern,

COP #2316-125- T&M in the amount of **\$352.41**.

DESCRIPTION	QTY	UNIT COST	UNIT EXT	LABOR HOURS	LABOR EXT
T & M on 8/30/2024	1		\$0.00	3	3
Weatherproof single gang cover	1	5	\$5.00		0
#12 THHN	30	0.26	\$7.80		0
1/2 Flex	2	1.65	\$3.30		0
1/2 Flex Connector	1	3	\$3.00		0
1/2 Flex 90	1	3	\$3.00		0
Subtotal			\$22.10		3.00
LABOR					
Electrician	3.00	\$76.48	\$229.44		
30% Insurance and Tax			\$68.83		
Total Labor			\$298.27		
Total Material			\$22.10		
Subtotal Labor and Material			\$320.37		
10% Overhead and Profit			\$32.04		
TOTAL CHANGE ORDER AMOUNT			\$352.41		

If you have any questions or concerns, please call our office.

Thank you,

Brad Kelloway
Project Manager

J
U
P
I
T
E
R
E
L
E
C
T
R
I
C
I
N
C.

JUPITER ELECTRIC, INC.
 142 B Lafayette Road
 Salisbury, Ma. 01952
 Phone:(978)499-7776
 Fax:(978)499-3838

Work Order

Work order #:

Date: 8/30/24

To: Bob Rice Pantry

Job: Straighton Fire 400 Prospect

Work Performed:

- Connect and mount (2) Displays for hood Fans
- Run Power (120v) from local ckt to Gas detection Panel in Maintenance Bay

MATERIAL

Quantity	Description
1	Weatherproof single gang cover (white)
30'	#12 THHN
2'	1/2" Flex
1	1/2" Flex 90 Conn
1	1/2" Flex straight conn
Labor	
	Steve Burke 7:30 - 10:30 3 hrs

TIME

Hours	Description	Total

Signature:



Title:

Date: 8-30-24

GGD Consulting Engineers, Inc.

M#91139
J#894 109 01.00

DATE: October 31, 2024

MEMO

TO: Kevin Seniw
Dore + Whittier

FROM: Jacob Duarte

David M. Pereira, P.E., Principal



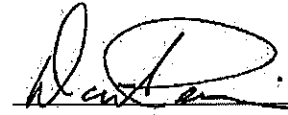

DEPT: Electrical

PROJECT: Stoughton Fire Station No. 1
Stoughton, MA

SUBJECT: PCO #083: CE #166-Add Outlet For Message Board

Please be advised as follows:

We have reviewed the Jupiter Electric, Inc. portion of Proposed Change Order No. 083 in the amount of \$425.06 for costs associated with adding an outlet for message board. We find the amount to be fair and reasonable and recommend your approval.

If you have any questions regarding this information, please contact our office at your earliest convenience.

JD:md

Enc.

Cc: Glen Gollrad, Dore + Whittier



Construction Managers

PCO #083

CTA Construction Managers
400 Totten Pond Road
Waltham, 02451
Phone: (781) 786-6600



Project: 2023-01 - Stoughton Fire Station No.01
400 Prospect Street
Stoughton, 02072

Prime Contract Potential Change Order #083: CE #166 - add outlet for message board

TO:	Town of Stoughton 10 Pearl St Stoughton Massachusetts, 02072	FROM:	CTA Construction Managers, LLC 400 Totten Pond Road, 2nd Floor Waltham Massachusetts, 02451
PCO NUMBER/REVISION:	083 / 0	CONTRACT:	1 - Stoughton Fire Station No 1
REQUEST RECEIVED FROM:		CREATED BY:	Jo-Ann Darrigo (CTA Construction Managers, LLC)
STATUS:	Pending - In Review	CREATED DATE:	9/27 /2024
REFERENCE:		PRIME CONTRACT CHANGE ORDER:	None
FIELD CHANGE:	No		
LOCATION:		ACCOUNTING METHOD:	Amount Based
SCHEDULE IMPACT:		PAID IN FULL:	No
		TOTAL AMOUNT:	\$446.31

POTENTIAL CHANGE ORDER TITLE: CE #166 - add outlet for message board

CHANGE REASON: Client Request

POTENTIAL CHANGE ORDER DESCRIPTION: (The Contract Is Changed As Follows)

CE #166 - add outlet for message board
verbal request for Jupiter to add an outlet for message board

*CTA reserves its rights to additional time and direct and indirect costs associated with this change order. CTA does not waive its rights to an additional extension of time or to recover additional costs by signing this change order. The Awarding Authority, in executing this change order, agrees that CTA has properly reserved its rights for additional time and compensation.

ATTACHMENTS:

2316-129 9.13.24 TM outlet for message board.pdf

#	Cost Code	Description	Type	Amount
1	16-100 - Electrical	add outlet	Filed Sub Bidder	\$ 425.08
Subtotal:				\$425.08
CTA Direct: 10.00% Applies to CTA Direct.				\$ 0.00
CTA Sub: 5.00% Applies to CTA Sub .				\$ 0.00
Filed Sub: 5.00% Applies to Filed Sub Bidder .				\$ 21.25
CTA Bonds & Insurance: 0.00% Applies to Filed Sub Bidder , CTA Sub , and CTA Direct.				\$ 0.00
Grand Total:				\$446.31

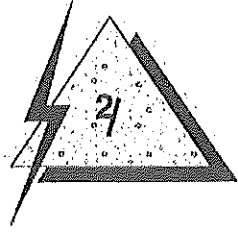

September 20, 2024

J
U
P
-
T
E
R
E
L
E
C
T
R
I
C
I
A
N
S

CTA Construction Managers
 400 Totten Pond Road
 2nd Floor
 Waltham, MA 02451
 Attn: Terry Vieux tvieux@ctaconstruction.com
 Paula Martin pmartin@ctaconstruction.com
 Tel: 781-786-6629

RE: **Stoughton Fire Station 400 Prospect Steet Stoughton, MA 02072 Change Order Proposal: #2316-129**

To Whom it May Concern,

COP #2316-129 – 9/13/24 T&M in the amount of **\$425.06.**

DESCRIPTION	QTY	UNIT COST	UNIT EXT	LABOR HOURS	LABOR EXT
T&M on 9/13/24	1		\$0.00	3	3
4sq Boxes	2	3.15	\$6.30		0
GFCI	1	25	\$25.00		0
Duplex Mulberry Cover	1	3.75	\$3.75		0
12/2 MC Cable	20	1.38	\$27.60		0
3/4 EMT	10	1	\$10.00		0
3/4 EMR Connectors	2	4.75	\$9.50		0
3/4 Plastic Bushings	1	1	\$1.00		0
Duplex Receptacle	1	5	\$5.00		0
			\$0.00		0
Subtotal			\$88.15		3.00
LABOR					
Electrician	3.00	\$76.48	\$229.44		
30% Insurance and Tax			\$68.83		
Total Labor			\$298.27		
Total Material			\$88.15		
Subtotal Labor and Material			\$386.42		
10% Overhead and Profit			\$38.64		
TOTAL CHANGE ORDER AMOUNT			\$425.06		

If you have any questions or concerns, please call our office.

Thank you,

Brad Kelloway
 Project Manager

JUPITER ELECTRIC, INC.
 142 B Lafayette Road
 Salisbury, Ma. 01952
 Phone:(978)499-7776
 Fax:(978)499-3838

Work Order

Work order #:

Date: 9/13/24

To: Bob Rice (Pom Roy)

Job: Straighten Fire

Work Performed:

Add Receptacle and 3/4" EMT For
 Alerting Message Board

MATERIAL

Quantity	Description
2	4" x 1 1/2" boxes
1	GFCI mulberry cover
1	Duplex mulberry cover
20'	12-2 MC
2	MC conn
10'	3/4" EMT
2	3/4" EMT conn.
1	3/4" Plastic Bushing
1	Duplex Receptacle
Labor Steve B 10:30 - 1:30	
3 hrs	

TIME

Hours	Description	Total

Signature: 

Title: OPM

Date: 9-13-24



PCO #083

CTA Construction Managers
 400 Totten Pond Road
 Waltham, 02451
 Phone: (781) 786-6600

Project: 2023-01 - Stoughton Fire Station No.01
 400 Prospect Street
 Stoughton, 02072

Prime Contract Potential Change Order #083: CE #166 - add outlet for message board

TO:	Town of Stoughton 10 Pearl St Stoughton Massachusetts, 02072	FROM:	CTA Construction Managers, LLC 400 Totten Pond Road, 2nd Floor Waltham Massachusetts, 02451
PCO NUMBER/REVISION:	083 / 0	CONTRACT:	1 - Stoughton Fire Station No 1
REQUEST RECEIVED FROM:		CREATED BY:	Jo-Ann Darrigo (CTA Construction Managers, LLC)
STATUS:	Pending - In Review	CREATED DATE:	9/27 /2024
REFERENCE:		PRIME CONTRACT CHANGE ORDER:	None
FIELD CHANGE:	No		
LOCATION:		ACCOUNTING METHOD:	Amount Based
SCHEDULE IMPACT:		PAID IN FULL:	No
		TOTAL AMOUNT:	\$446.31

POTENTIAL CHANGE ORDER TITLE: CE #166 - add outlet for message board

CHANGE REASON: Client Request

POTENTIAL CHANGE ORDER DESCRIPTION: *(The Contract Is Changed As Follows)*

CE #166 - add outlet for message board
 verbal request for Jupiter to add an outlet for message board

*CTA reserves its rights to additional time and direct and indirect costs associated with this change order. CTA does not waive its rights to an additional extension of time or to recover additional costs by signing this change order. The Awarding Authority, in executing this change order, agrees that CTA has properly reserved its rights for additional time and compensation.

ATTACHMENTS:

2316-129 9.13.24 TM outlet for message board.pdf

#	Cost Code	Description	Type	Amount
1	16-100 - Electrical	add outlet	Filed Sub Bidder	\$ 425.06
Subtotal:				\$425.06
CTA Direct: 10.00% Applies to CTA Direct.				\$ 0.00
CTA Sub: 5.00% Applies to CTA Sub .				\$ 0.00
Filed Sub: 5.00% Applies to Filed Sub Bidder .				\$ 21.25
CTA Bonds & Insurance: 0.00% Applies to Filed Sub Bidder , CTA Sub , and CTA Direct.				\$ 0.00
Grand Total:				\$446.31

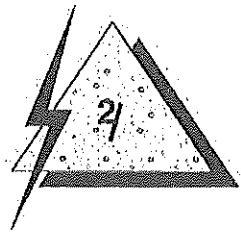

September 20, 2024

J
U
P
I
T
E
R

E
L
E
C
T
R
I
C
A
L

I
N
C.

CTA Construction Managers
 400 Totten Pond Road
 2nd Floor
 Waltham, MA 02451
 Attn: Terry Vieux tvieux@ctaconstruction.com
 Paula Martin pmartin@ctaconstruction.com
 Tel: 781-786-6629

RE: **Stoughton Fire Station 400 Prospect Steet Stoughton, MA 02072 Change Order Proposal: #2316-129**

To Whom it May Concern,

COP #2316-129 – 9/13/24 T&M in the amount of \$425.06.

DESCRIPTION		UNIT	UNIT	LABOR	LABOR
MATERIAL	QTY	COST	EXT	HOURS	EXT
T&M on 9/13/24	1		\$0.00	3	3
4sq Boxes	2	3.15	\$6.30		0
GFCI	1	25	\$25.00		0
Duplex Mulberry Cover	1	3.75	\$3.75		0
12/2 MC Cable	20	1.38	\$27.60		0
3/4 EMT	10	1	\$10.00		0
3/4 EMR Connectors	2	4.75	\$9.50		0
3/4 Plastic Bushings	1	1	\$1.00		0
Duplex Receptacle	1	5	\$5.00		0
			\$0.00		0
Subtotal			\$88.15		3.00
LABOR					
Electrician	3.00	\$76.48	\$229.44		
30% Insurance and Tax			\$68.83		
Total Labor			\$298.27		
Total Material			\$88.15		
Subtotal Labor and Material			\$386.42		
10% Overhead and Profit			\$38.64		
TOTAL CHANGE ORDER AMOUNT			\$425.06		

If you have any questions or concerns, please call our office.

Thank you,

Brad Kelloway
 Project Manager

JUPITER ELECTRIC, INC.
 142 B Lafayette Road
 Salisbury, Ma. 01952
 Phone:(978)499-7776
 Fax:(978)499-3838

Work Order

Work order #:

Date: 9/13/24

To: Bob Rice (Pam Ray)

Job: Straighten Fire

Work Performed:

Add Receptacle and 3/4" EMT For
 Alerting Message Board

MATERIAL

Quantity	Description
2	4" x 1 1/2" boxes
1	GFCI mulberry cover
1	Duplex mulberry cover
20'	12-2 MC
2	MC conn
10'	3/4" EMT
2	3/4" EMT conn.
1	3/4" Plastic Bushing
1	Duplex Receptacle
Labor Steve B 10:30 - 1:30	
3hrs	

TIME

Hours	Description	Total

Signature: 

Title: OPM

Date: 9-13-24

GGD Consulting Engineers, Inc.

M#91140
J#894 109 01.00

DATE: October 31, 2024

MEMO

TO: Kevin Seniw
Dore + Whittier

FROM: Jacob Duarte

David M. Pereira, P.E., Principal



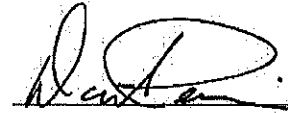

DEPT: Electrical

PROJECT: Stoughton Fire Station No. 1
Stoughton, MA

SUBJECT: PCO #085: CE #148-Revise Electrical For Owners SCBA And Compressor

Please be advised as follows:

We have reviewed the Jupiter Electric, Inc. portion of Proposed Change Order No. 085 in the amount of \$920.53 for costs associated with revising SCBA power feed and add fuse reducer. We find the amount to be fair and reasonable and recommend your approval.

If you have any questions regarding this information, please contact our office at your earliest convenience.

JD:md

Enc.

Cc: Glen Gollrad, Dore + Whittier



Construction Managers

PCO #085

CTA Construction Managers
400 Totten Pond Road
Waltham, 02451
Phone: (781) 786-6600



Project: 2023-01 - Stoughton Fire Station No.01
400 Prospect Street
Stoughton, 02072

Prime Contract Potential Change Order #085: CE #148 - revise electrical for owners scba and compressor

TO:	Town of Stoughton 10 Pearl St Stoughton Massachusetts, 02072	FROM:	CTA Construction Managers, LLC 400 Totten Pond Road, 2nd Floor Waltham Massachusetts, 02451
PCO NUMBER/REVISION:	085 / 0	CONTRACT:	1 - Stoughton Fire Station No 1
REQUEST RECEIVED FROM:		CREATED BY:	Jo-Ann Darrigo (CTA Construction Managers, LLC)
STATUS:	Pending - In Review	CREATED DATE:	9/27 /2024
REFERENCE:		PRIME CONTRACT CHANGE ORDER:	None
FIELD CHANGE:	No		
LOCATION:		ACCOUNTING METHOD:	Amount Based
SCHEDULE IMPACT:		PAID IN FULL:	No
		TOTAL AMOUNT:	\$966.56

POTENTIAL CHANGE ORDER TITLE: CE #148 - revise electrical for owners scba and compressor

CHANGE REASON: Client Request

POTENTIAL CHANGE ORDER DESCRIPTION: *(The Contract Is Changed As Follows)*
CE #148 - revise electrical for owners scba and compressor
rfi 144 and rfi 145-revise scba power feed and add fuse reducer

NOTE: D+W ADDED ALL PERTINENT BACK-UP REQUIRED TO REVIEW PCO IN ITS ENTIRETY

*CTA reserves its rights to additional time and direct and indirect costs associated with this change order. CTA does not waive its rights to an additional extension of time or to recover additional costs by signing this change order. The Awarding Authority, in executing this change order, agrees that CTA has properly reserved its rights for additional time and compensation.

ATTACHMENTS:

2316-128 9.13.24 TM scba compressor fuse reducer.pdf 2316-130 9.17.24 TM scba washer outlet; unit came with cord vs hard wire.pdf

#	Cost Code	Description	Type	Amount
1	16-100 - Electrical	revise power feed	Filed Sub Bidder	\$ 196.07
2	16-100 - Electrical	add fuse reducer	Filed Sub Bidder	\$ 724.46
Subtotal:				\$920.53
CTA Direct: 10.00% Applies to CTA Direct.				\$ 0.00
CTA Sub: 5.00% Applies to CTA Sub .				\$ 0.00
Filed Sub: 5.00% Applies to Filed Sub Bidder .				\$ 46.03
CTA Bonds & Insurance: 0.00% Applies to Filed Sub Bidder , CTA Sub , and CTA Direct.				\$ 0.00
Grand Total:				\$966.56

RECEIVED
FROM CONSULTANT

08/29/2024

Dore + Whittier Architects, Inc.
Architects • Project Managers
Burlington, VT

GGD Consulting Engineers, Inc.

REQUEST FOR INFORMATION - RFI

M#90312
J#894 109 01.00

DATE: August 28, 2024

TO: Kevin Seniw
Dore + Whittier

FROM: Jacob Duarte



DEPT: Electrical

PROJECT: Stoughton Fire Station No. 1
Stoughton, MA

SUBJECT: RFI #144: SCBA Power Feed

Question:

See attached electrical question on SCBA power feed attachment. Please advise what to do.

Response:

Electrical Contractor to install a 3-phase receptacle matching the Nema rating of the plug.

JD:md

Enc.

Cc: Heather Gratton, Dore + Whittier
Glen Gollrad, Dore + Whittier

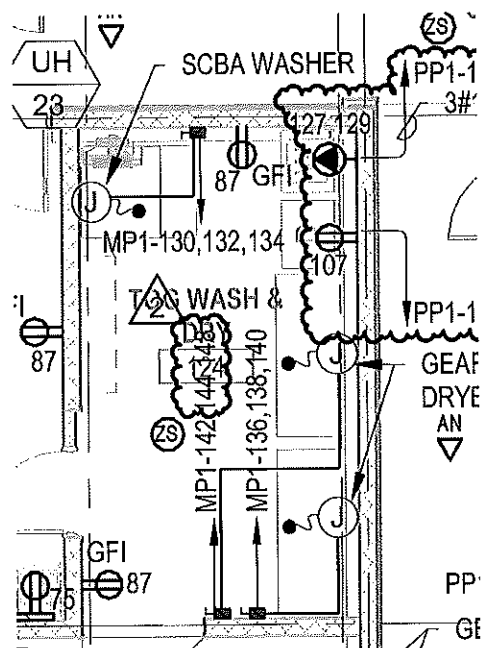

RECEIVED

08/20/2024

Dore + Whittier Architects, Inc.
Architects • Project Managers
Burlington, VT

RECEIVED

8/26/24

GGD Consulting Engineers, Inc.

REQUEST FOR INTERPRETATION FORM

STOUGHTON FIRE STATION - #19-0796

TO:

Dore & Whittier Architects Inc.
260 Merrimac St., Bldg.7
Newburyport, MA 01950

FROM:

J Darrigo- CTA

RFI #:

144

Attn: Kevin Seniw

Reply Requested by:
08/22/2024

Issue Date:
08/20/2024

RFI DESCRIPTION (Indicate origin of RFI, and summarize the question or type of information required):

see attached electrical questio on SCBA power feed attachment. please advise what to do

REFERENCES (List relevant Drawings or Specification sections and paragraphs):

SENDER'S RECOMMENDATION (All RFIs must include a contractor's recommended solution to each condition, including a statement of cost or schedule of impact if applicable.

The contractor may be back-charged by the Town of Stoughton for designer's review time for any RFI submitted without a sender's recommended solution or where response is evident in Drawings.)

DESIGNER'S RESPONSE:

Per engineers response, Electrical Contractor to install a 3-phase receptacle matching the Nema rating of the plug.

BY:

Kevin Seniw
Contact Info:
kseniw@doreandwhittier.com
Date: 2024.09.03

DATE:

COPIES TO:

Jupiter Electric, Inc.
142B Lafayette Road
Salisbury, MA 01952
Phone (978)499-7776 /Fax (978)499-3838
ndjupiterelectric@outlook.com

REQUEST FOR INFORMATION

REQUEST # 44

JOB: Stoughton Fire Station

TO: tvieux@ctaconstruction.com

ATTENTION: Terry Vieux

Date: August 20, 2024

RE: E2.10

Question: E2.10 calls for SCBA washer to have a 3 phase 208v 40 amp disconnect with a whip to feed the equipment. The washer is currently on site and was equipped with a 3 phase 208v plug on the end. Please advise.

Response:

Jupiter Electric Representative: Brad Kelloway

Attachments: NO Answer required by:



DECON FOR HEROES™

EASY DECONTAMINATION
OF COMPLETE SCBA

Developed in cooperation with

HEALTH

Solo Rescue®
SCBA DECON WASHER

CONTAMINATED GEAR IS A CONSTANT HEALTH RISK.

The SCBA (Self Contained Breathing Apparatus) and protective gear are a lifeline for firefighters in their daily work of saving the lives of others.

When fighting a fire, soot particles and combustion gases are absorbed by the protective gear. This contamination then poses a health risk to the firefighter. Therefore it is important to decontaminate the protective gear immediately upon return to the station.

CLEANING BY HAND IS TIME CONSUMING, HARD WORK AND POSES A HEALTH RISK.

Cleaning contaminated gear by hand takes time (about 30 minutes/set) and is hardly what you want to be doing after a demanding operation in the field. Cleaning by hand also means that the crew is yet again exposed to the residues from combustion gases, soot particles and toxins. Only this time, unprotected.

Studies have shown that prolonged exposure to these toxins put firefighters at greater risk of developing cancer than other professional groups. Establishing procedures to handle contaminated gear in a controlled and safe way is one way of minimizing this risk.

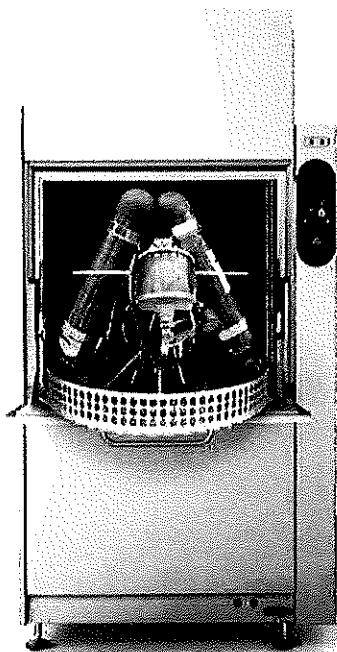

SOLO RESCUE® – CLEAN GEAR IN A FEW MINUTES.

The Solo Rescue cleans SCBAs and protective gear of residue from combustion gases, soot particles and other toxins in just a few minutes. It can clean steel, composite, rubber, fabric, plastic, etc. all in a mechanical, self contained process.

IMPROVED WORKING ENVIRONMENT AND MINIMISED CONTACT TIME.

The Solo Rescue offers a quick, easy and safe method of cleaning protective gear in a sealed compartment. This ergonomic process minimizes manual contact with contaminated materials.

The Solo Rescue does the hard work for you. This significantly improves the work environment for rescue services personnel.

DEVELOPED IN CLOSE COOPERATION WITH THE SWEDISH RESCUE SERVICE.

The Solo Rescue was developed in close cooperation with the Swedish Rescue Services. The goal of this partnership was to develop a healthier way to decontaminate protective gear. The Solo Rescue has a durable stainless steel interior with heavy duty stainless steel accessories for cleaning SCBAs, gloves, helmets, and boots.

COMPACT, EASY AND EFFICIENT.

Fits in less than 11 ft².

Solo Rescue is a compact machine with a lower door that folds out, acting as a loading table when opened. The machine occupies less than 11 ft² of space.

Self-contained cleaning process.

The entire cleaning process is carried out inside in the machine, ensuring minimum contact time for the staff.

Two efficient wash programs.

Gear is cleaned in just a few minutes. Choose between a 3 min cycle for gloves and helmets or a 8 min cycle for SCBAs.

Watch our Solo Rescue videos on YouTube and follow us on LinkedIn for latest information.



Lightweight, compact and easy to use
 developed to fit the Solo Rescue Services.

INCLUDED.

All you need to clean single and double cylinder SBCA's is included with standard delivery of Solo Rescue®.

The heavy duty basket is used at all times and is paired with accessories to wash different gear. The SCBA holders are placed over the center bracket of the basket. The gear holder for gloves helmets and boots is placed in the bottom of the basket.

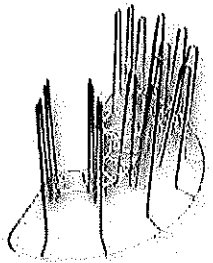

Gear holder for masks, helmets, gloves and boots. One holder is included.

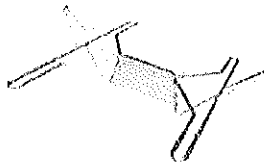

Holder for SCBA single/double cylinders. One holder is included.

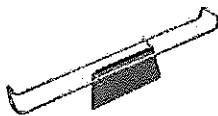

Holder for SCBA jumbo cylinders. One holder is included.



SCBA - capacity/hour.

The heavy duty basket, one SCBA holder for single and double cylinders, one SCBA holder for jumbo cylinders and one gear holder are included with the Solo Rescue®. The machine cleans up to 14 SCBAs/hour.

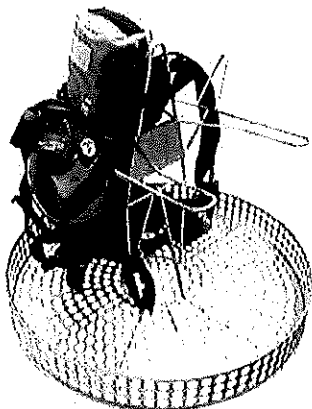

Heavy duty basket with holder for SCBA single/double cylinders.

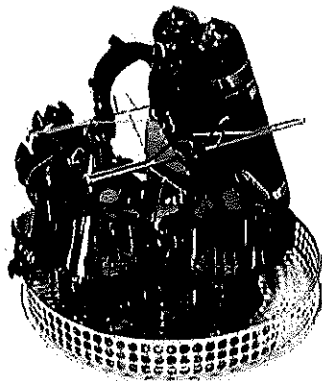

Heavy duty basket with holder for SCBA single/double cylinders and one gear holder for masks, helmets, gloves and/or boots.

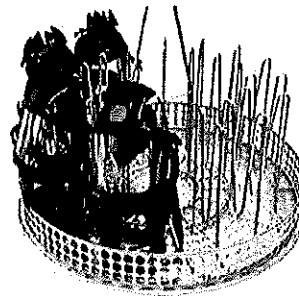

Heavy duty basket with two gear holders for masks, helmets, gloves and/or boots (one is included).

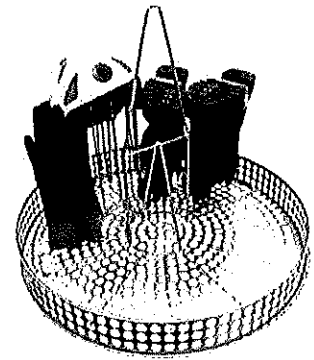

Heavy duty basket with one gear holder for masks, helmets, gloves and/or boots.

OPTIONAL.

OPTIONAL GEAR HOLDER FOR 60 HELMETS, 120 PAIRS OF GLOVES OR 40 PAIRS OF BOOTS* (capacity/hour).

Use the gear holder accessory to load and wash helmets, gloves and boots. It fits in the bottom of the heavy duty basket. Full capacity requires two gear holders (one is included as standard equipment).

60



HELMETS* - capacity/hour.

1 gear holder: up to 30 helmets.
 2 gear holders: up to 60 helmets.
 (max. 5 helmets/basket)

120



GLOVES* - capacity/hour.

1 gear holder: up to 60 pairs of gloves.
 2 gear holders: up to 120 pairs of gloves.

40



BOOTS* - capacity/hour.

1 gear holder: up to 20 pairs of boots.
 2 gear holders: up to 40 pairs of boots.

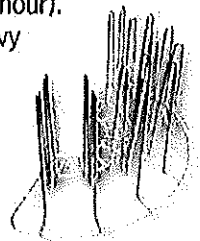

* Always follow the manufacturers washing guidelines. In case of uncertainty, contact your supplier for advice.

INSTALLATION DRAWING.

A. Water connection: 3-10 gpg, 4 gals./min B. Detergent connection C. Electrical connection: 40 A D. Drain: Ø 1-1/4". Minimum capacity 13 gals./min
 Important Note: Ventilation capacity: 300 CFM.

Important Note: All dimensions from floor +/- 1" due to adjustable feet

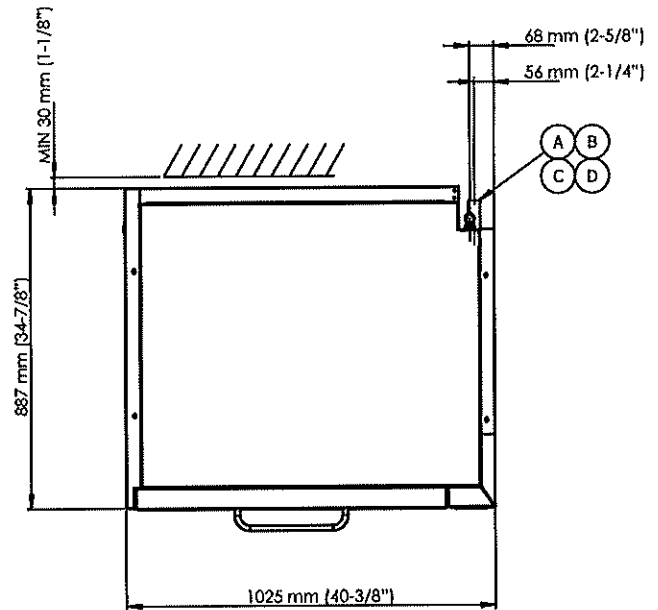
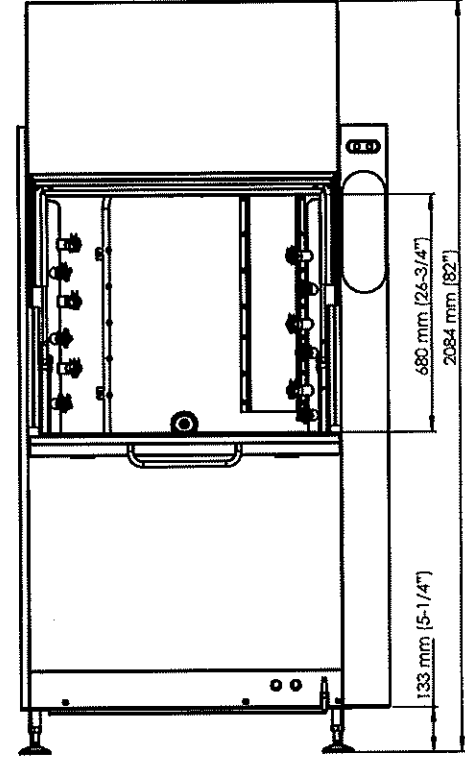
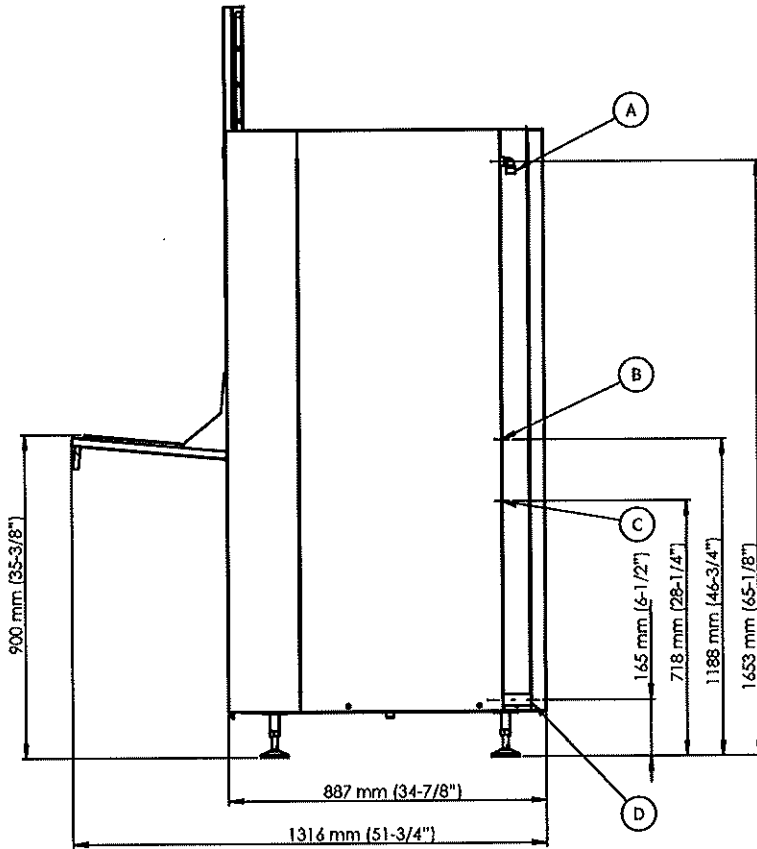

TECHNICAL SPECIFICATION	Hot water connection (standard) 3-ph/208 V/60Hz 3-ph/240 V/60Hz
Wash program lengths	3 min - gloves/helmets/boots 8 min - SCBA
Normal capacity per hour program length includes handling	14 SCBA* or up to 60 helmets, or up to 120 pairs of gloves, or 40 pairs of boots
Wash temperature	110-131 °F
Water supply	3-10 gpg
Pressure, incoming water	14,5-87 psi
External dimensions H x W x D	69" (open 82") x 40" x 35" (open 52")
Fuse	40 A

* single or double cylinders, with or without breathing mask.



RESCUE INTELLITECH Inc.
 19308 Morton Road, Suite 105, Katy, TX 77449
 Email: sales@rescue-tech.com
 www.solorescue.com
 Phone: 1-832-321-3260



Manufactured in Sweden in a CO₂ neutral production process according to ISO 9001:215 and ISO 14001:215.



© RESCUE INTELLITECH AB 2010.2. DESIGN INTELLITECH reserves the right to make technical changes to the product. No responsibility will be accepted for any similar names.

RECEIVED

08/20/2024

Dore + Whittier Architects, Inc.
Architects • Project Managers
Burlington, VT

RECEIVED

8/26/24

GGD Consulting Engineers, Inc.

REQUEST FOR INTERPRETATION FORM

STOUGHTON FIRE STATION - #19-0796

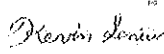
TO: Dore & Whittier Architects Inc. 260 Merrimac St., Bldg.7 Newburyport, MA 01950	FROM: J Darrigo- CTA	RFI #: 145
Attn: Kevin Senlw	Reply Requested by: 08/22/2024	Issue Date: 08/20/2024
RFI DESCRIPTION (Indicate origin of RFI, and summarize the question or type of information required): see attached electrical question on owner equipt Jupiter rfi 45		
REFERENCES (List relevant Drawings or Specification sections and paragraphs):		
SENDER'S RECOMMENDATION (All RFIs must include a contractor's recommended solution to each condition, including a statement of cost or schedule of impact if applicable. The contractor may be back-charged by the Town of Stoughton for designer's review time for any RFI submitted without a sender's recommended solution or where response is evident in Drawings.)		
DESIGNER'S RESPONSE: Refer to Engineers response. Also refer to ASI 13 which was issued for clarification back on March 15, 2024.		
BY:  <small>Digitally signed by Kevin Senlw Contact Info: ksenlw@doreandwhitfir.com Date: 2024.09.03</small>	DATE:	COPIES TO:

RECEIVED
FROM CONSULTANT
08/29/2024

Dore + Whittier Architects, Inc.
Architects • Project Managers
Burlington, VT

GGD Consulting Engineers, Inc.

REQUEST FOR INFORMATION - RFI

M#90313
J#894 109 01.00

DATE: August 28, 2024

TO: Kevin Senlw
Dore + Whittier

FROM: Jacob Duarte



DEPT: Electrical

PROJECT: Stoughton Fire Station No. 1
Stoughton, MA

SUBJECT: RFI #145: Compressor Feed

Question:

See attached electrical question on owner equipped Jupiter RFI 45

Response:

The contract documents show a fused disconnect, Electrical Contractor to utilize 40 Amp fuses and utilize 4#8, #10G-1" C from load side of disconnect to SCBA compressor.

JD:md

Enc.

Cc: Heather Gratton, Dore + Whittier
Glen Gollrad, Dore + Whittier

Jupiter Electric, Inc.
142B Lafayette Road
Salisbury, MA 01952
Phone (978)499-7776 /Fax (978)499-3838
ndjupiterelectric@outlook.com

REQUEST FOR INFORMATION

REQUEST # 45

JOB: Stoughton Fire Station

TO: tvieux@ctaconstruction.com

ATTENTION: Terry Vieux

Date: August 20, 2024

RE: E2.10 & E3.00

Question: E2.10 and E3.00 call for the SCBA compressor to have a 100-amp 3 phase disconnect fed from NEDP 90 amp breaker. The equipment is on site and installed but FLA is 27 amps. The cheapest solution is changing the 100 amp disconnect to a fuses disconnect and installing fuse reducers down to a 30 amp fuse. The #1 thhn will not fit in a lower amp disconnects lugs. Please advise.

Response:

Jupiter Electric Representative: Brad Kelloway
Attachments: Yes Answer required by:

16

15

14

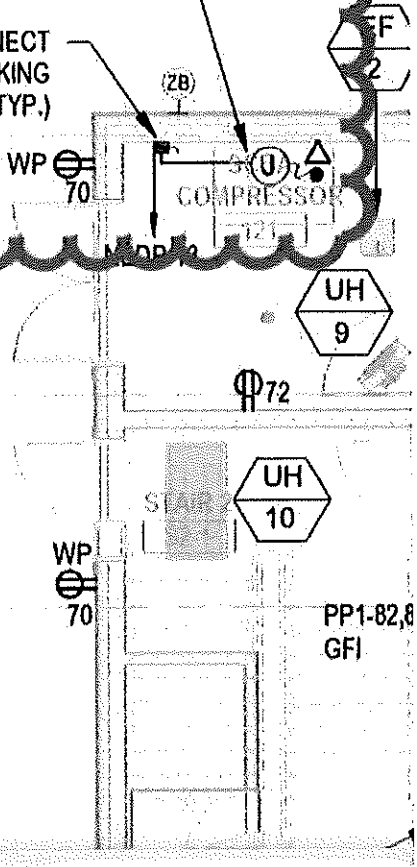
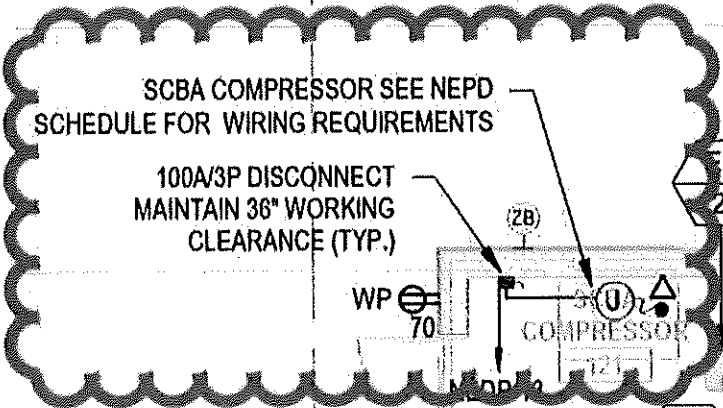

1200 AMP, 120/208 V, 3 PHASE, 4W
AIC: 42,000
MLO

DISTRIBUTION PANI

OVER CURRENT DEVICES			CIRCUIT	FEEDER SIZE
No.	TRIP	FRAME		
-	1000	1000	MAIN BREAKER	SEE RISER
1	60	100	SURGE PROTECTION DEVICE (SPD)	4#6 & #10G
2	225	225	PANEL PP1	4#4/0 & #4G
3	400	400	PANEL MP1	4#600kCMIL & #3G
4	100	100	PANEL LP1	4#1 & #8G
5	60	100	PANEL TEP	4#4 & #10G
6	175	225	ELEVATOR	4#2/0 & #6G
7	60	100	PANEL KP	4#4 & #10G
8	125	225	RTU-1	4#1 & #6G
9	100	100	RTU-2	4#1 & #6G
10	80	100	VRFC-1	4#3 & #8G
11	60	100	VEF-1 (10 HP)	4#4 & #10G
12	100	100	PANEL MBP	4#1 & #8G
13	90	100	SCBA COMPRESSOR	4#1 & #8G
	100	100	SPARE	
15	225	225	SPARE	-
16	-	225	SPACE	-
16	-	225	SPACE	-

VERTECON®

BAUER
COMPRESSORS

Quality. Our DNA

3, 4 AND 5-STAGE OPEN HIGH PRESSURE BREATHING AIR COMPRESSORS

BAUER's VERTECON series of high pressure breathing air compressor systems have been an industry leader for many years. An economical design featuring the latest BAUER technological enhancements and unsurpassed maintenance accessibility are incorporated within the simplistic platform. The series now features an integral base which eliminates the guess work of product placement, insuring the system has been installed correctly for system ventilation and maintenance accessibility. With the advent of the integral base the compressor package also has the ability of having a sound attenuated enclosure optionally installed at a later date. A refreshed HMI operations panel and electrical control system allow you to tailor the system to your specific requirements. When simple is what you want look to BAUER.

› **PRESSURE:**

Up to 6000 PSIG
(414 BAR)

› **CHARGING RATE:**

5 to 26.4 SCFM
(142 to 748 L/MIN)

› **POWER:**

5 to 20 HP (3.7 to 15 kW)

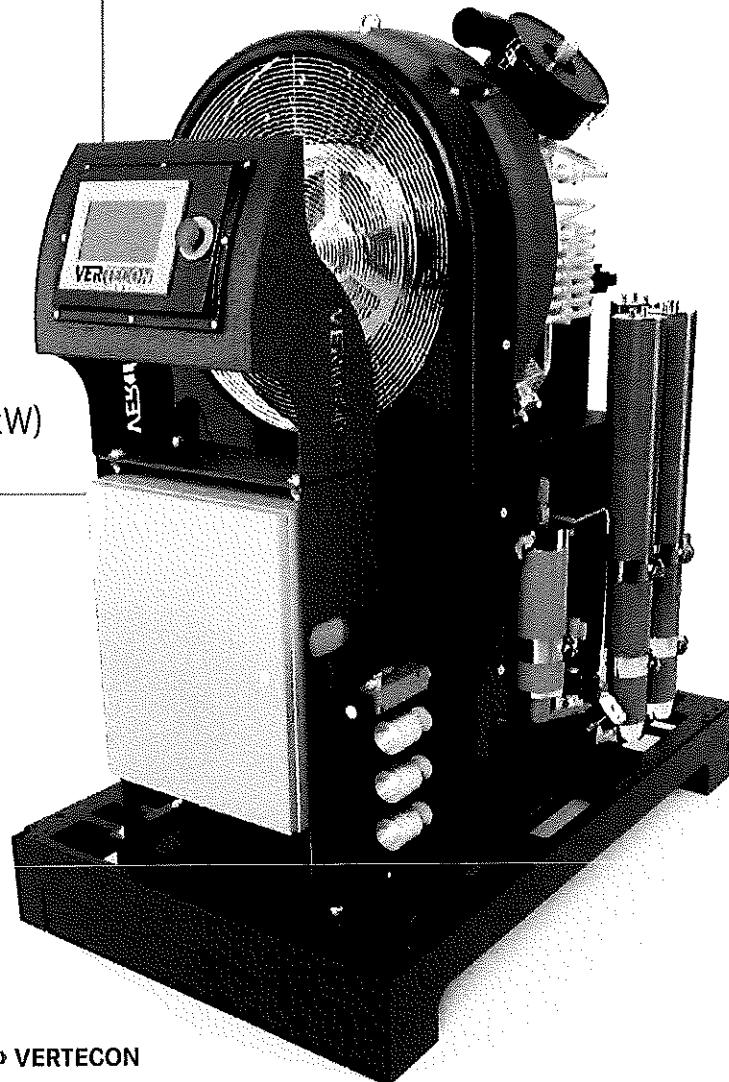

› VERTECON

STANDARD SCOPE OF SUPPLY

- › BAUER breathing air purification system
- › Open vertical cabinet made of formed sheet and plate goods provide a firm foundation for all pressure bearing components
- › Modern design with unsurpassed maintenance accessibility (no hand tools are required for normal maintenance checks and fluid level confirmation)
- › BAUER PLC based controller with 7" color HMI touchscreen display
- › Belt adjustment tool
- › NEMA 4 rated electrical enclosure with **UL®** listed control panel
- › All wiring harnesses incorporated within a corrugated loom with number coding for easy system diagnosis
- › Emergency stop push button
- › .049 wall thickness stainless steel tubing throughout, no cheap plastic tubing
- › Rugged powder coat finish
- › Zero loss automatic condensate drain system
- › Interstage pressure gauges (locally mounted)
- › Compressor on/off, final pressure, oil pressure and high temperature shutdown
- › Motor overload indication
- › Final separator counter with shutdown and operator indication
- › Unique integrated positioning base which ensures correct installation everytime

AVAILABLE ACCESSORIES (FACTORY INSTALLED)

- › CO monitoring system
- › SECURUS - Electronic moisture monitoring for the purification system
- › B-Kool (floor mount only)
- › H₂S monitoring system with audible alarm
- › Insulated sound attenuated cabinet

SYSTEM FOOTPRINT

VEC05 - VEC13:

DIMENSIONS L X W X H inches (mm)

› 54" x 34" x 56" (1372.6mm x 863.6mm x 1422.4mm)

› WEIGHT pounds (kg)

› 800 - 900 lb (363 - 408.2 kg)

VEC18 - VEC26:

DIMENSIONS L X W X H inches (mm)

› 54" x 34" x 63" (1372.6mm x 863.6mm x 1600.2mm)

› WEIGHT pounds (kg)

› 1200 - 1300 lb (544.3 - 589.7 kg)

TECHNICAL DATA

Model	Charging Rate ¹		Number of Stages	Motor		FAD ²	RPM	Purification System
	SCFM	L/MIN		HP	KW			
5000 PSIG (345 BAR)								
VEC08-E1/E3	8.4	238	3	7.5	5.6	7	1250	P31
VEC20-E3	21	595	4	15	11	17.5	1300	P5
VEC26-E3	26.4	748	4	20	15	22	1350	P5
6000 PSIG (414 BAR)								
VEC05-E1/E3	5	142	3	5	3.7	4	1050	P2
VEC10-E1/E3	9.7	275	4	7.5	5.6	8.1	1180	P2
VEC13-E1/E3	13	368	4	10	7.5	10.8	1420	P2
VEC18-E3	18	510	4	15	11	15	1325	P5
VEC25-E3	25.2	714	5	20	15	21	1300	P5

1) Based on recharging an 80 cubic foot tank from 500 to 3000 psig.

2) Compressor capacity referenced to standard inlet conditions.

E1= Single phase electric, 230 VAC/60 Hz. E3=Three phase electric, 208/230/460 VAC/60 Hz. Other voltages available on request. Dimensions and weight are approximate and are subject to change.

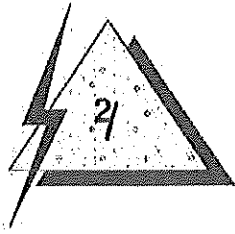

September 20, 2024

J
U
P
I
T
E
R
E
L
E
C
T
R
I
C
I
N
C.

CTA Construction Managers
 400 Totten Pond Road
 2nd Floor
 Waltham, MA 02451
 Attn: Terry Vieux tvieux@ctaconstruction.com
 Paula Martin pmartin@ctaconstruction.com
 Tel: 781-786-6629

RE: **Stoughton Fire Station 400 Prospect Steet Stoughton, MA 02072 Change Order Proposal: #2316-130**

To Whom it May Concern,

COP #2316-130 – 9/17/24 T&M in the amount of \$196.07.

DESCRIPTION		UNIT	UNIT	LABOR	LABOR
MATERIAL	QTY	COST	EXT	HOURS	EXT
T&M on 9/17/24	1		\$0.00	1	1
4sq Boxes	2	3.15	\$6.30		0
2 Gang Plaster Ring	1	3	\$3.00		0
3 Phase Plug	1	55.52	\$55.52		0
3/4 EMT	10	1	\$10.00		0
3/4 Support	1	1	\$1.00		0
50a Stainless Cover	1	3	\$3.00		0
			\$0.00		0
			\$0.00		0
			\$0.00		0
Subtotal			\$78.82		1.00
LABOR					
Electrician	1.00	\$76.48	\$76.48		
30% Insurance and Tax			\$22.94		
Total Labor			\$99.42		
Total Material			\$78.82		
Subtotal Labor and Material			\$178.24		
10% Overhead and Profit			\$17.82		
TOTAL CHANGE ORDER AMOUNT			\$196.07		

If you have any questions or concerns, please call our office.

Thank you,

Brad Kelloway
 Project Manager

142 B Lafayette Road
Salisbury, Ma. 01952
Phone:(978)499-7776
Fax:(978)499-3838

Work Order

Work order #:

Date: 9/17/24

To: Bob Rice (Pan Ray)

Job: Stoughton Fire

Work Performed:

3Ø 208V Plug for SeBA washer

MATERIAL

Quantity	Description
1	4" Square Box 2-1/4 deep
1	2 Gang Plaster Ring
1	3Ø 208 volt Plug
10'	3/4" EMT
1	3/4" Clip
1	50 amp Stainless 2 Gang Plate
	Labor 1 hrs Steve Burke

TIME

Hours	Description	Total

Signature: 

Title: OPM

Date: 9-17-24

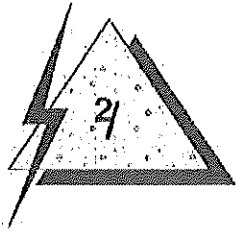

September 20, 2024

J
U
P
-
T
E
R
R
E
L
E
C
T
R
I
C
I
A
N
C.

CTA Construction Managers
400 Totten Pond Road
2nd Floor
Waltham, MA 02451
Attn: Terry Vieux tvieux@ctaconstruction.com
Paula Martin pmartin@ctaconstruction.com
Tel: 781-786-6629

RE: **Stoughton Fire Station 400 Prospect Steet Stoughton, MA 02072 Change Order Proposal: #2316-128**

To Whom it May Concern,

COP #2316-128 – 9/13/24 T&M in the amount of **\$724.46.**

DESCRIPTION	QTY	UNIT COST	UNIT EXT	LABOR HOURS	LABOR EXT
T&M on 9/13/24	1		\$0.00	3	3
Fuse Reducers	3	120.11	\$360.33		0
			\$0.00		0
Subtotal			\$360.33		3.00
LABOR					
Electrician	3.00	\$76.48	\$229.44		
30% Insurance and Tax			\$68.83		
Total Labor			\$298.27		
Total Material			\$360.33		
Subtotal Labor and Material			\$658.60		
10% Overhead and Profit			\$65.86		
TOTAL CHANGE ORDER AMOUNT			\$724.46		

If you have any questions or concerns, please call our office.

Thank you,

Brad Kelloway
Project Manager

JUPITER ELECTRIC, INC.
142 B Lafayette Road
Salisbury, Ma. 01952
Phone:(978)499-7776
Fax:(978)499-3838

Work Order

Work order #:

Date: 9/13/24

To: Bob (Pamrey)

Job: Straighten Fire

Work Performed:

SCBA compressor Disconnect Fuse Down from
90 amp to 50 amp

MATERIAL

Quantity	Description
3	Fuse Reducers 100 amp to 60 amp
	Labor Steve B. 7:30 - 10:30
	3 hrs

TIME

Hours	Description	Total

Signature:

Title:

OPM

Date:

9/13/24

GGD Consulting Engineers, Inc.

M#91141
J#894 109 01.00

DATE: October 31, 2024

MEMO

TO: Kevin Seniw
Dore + Whittier

FROM: Jacob Duarte

David M. Pereira, P.E., Principal





DEPT: Electrical

PROJECT: Stoughton Fire Station No. 1
Stoughton, MA

SUBJECT: PCO #086: CE #159-RFI 155-Wire LGE Icemaker

Please be advised as follows:

We have reviewed the Jupiter Electric, Inc. portion of Proposed Change Order No. 086 in the amount of \$358.84 for costs associated with wiring LGE icemaker. We find the amount to be fair and reasonable and recommend your approval.

1. Would consider revising change order title as labor hours also include testing for fire suppression system in kitchen.

If you have any questions regarding this information, please contact our office at your earliest convenience.

JD:md

Enc.

Cc: Glen Gollrad, Dore + Whittier



Construction Managers

PCO #086

CTA Construction Managers
400 Totten Pond Road
Waltham, 02451
Phone: (781) 786-6600



Project: 2023-01 - Stoughton Fire Station No.01
400 Prospect Street
Stoughton, 02072

Prime Contract Potential Change Order #086: CE #159 - rfi 155- wire lge icemaker

TO:	Town of Stoughton 10 Pearl St Stoughton Massachusetts, 02072	FROM:	CTA Construction Managers, LLC 400 Totten Pond Road, 2nd Floor Waltham Massachusetts, 02451
PCO NUMBER/REVISION:	086 / 0	CONTRACT:	1 - Stoughton Fire Station No 1
REQUEST RECEIVED FROM:		CREATED BY:	Jo-Ann Darrigo (CTA Construction Managers, LLC)
STATUS:	Pending - In Review	CREATED DATE:	9/27 /2024
REFERENCE:		PRIME CONTRACT CHANGE ORDER:	None
FIELD CHANGE:	No		
LOCATION:		ACCOUNTING METHOD:	Amount Based
SCHEDULE IMPACT:		PAID IN FULL:	No
		TOTAL AMOUNT:	\$376.78

POTENTIAL CHANGE ORDER TITLE: CE #159 - rfi 155- wire lge icemaker

CHANGE REASON: Client Request

POTENTIAL CHANGE ORDER DESCRIPTION: (The Contract Is Changed As Follows)

CE #159 - rfi 155- wire lge icemaker
rfi 155- wire ice maker

*CTA reserves its rights to additional time and direct and indirect costs associated with this change order. CTA does not waive its rights to an additional extension of time or to recover additional costs by signing this change order. The Awarding Authority, in executing this change order, agrees that CTA has properly reserved its rights for additional time and compensation.

ATTACHMENTS:

2316-127 9.10.24 TM wire ice machine.pdf

#	Cost Code	Description	Type	Amount
1	16-100 - Electrical	wire ice maker	Filed Sub Bidder	\$ 358.84
			Subtotal:	\$358.84
			CTA Direct: 10.00% Applies to CTA Direct.	\$ 0.00
			CTA Sub: 5.00% Applies to CTA Sub .	\$ 0.00
			Filed Sub: 5.00% Applies to Filed Sub Bidder .	\$ 17.94
			CTA Bonds & Insurance: 0.00% Applies to Filed Sub Bidder , CTA Sub , and CTA Direct.	\$ 0.00
			Grand Total:	\$376.78

RECEIVED

09/09/2024

Dore + Whittier Architects, Inc.
Architects • Project Managers
Burlington, VT

**RECEIVED
FROM CONSULTANT**

09/10/2024

Dore + Whittier Architects, Inc.
Architects • Project Managers
Burlington, VT

9/9/24

RECEIVED

GGD Consulting Engineers, Inc.

REQUEST FOR INTERPRETATION FORM

STOUGHTON FIRE STATION - #19-0796

TO: Dore & Whittier Architects Inc. 260 Merrimac St., Bldg.7 Newburyport, MA 01950	FROM: J Darrigo- CTA	RFI #: 155
Attn: Kevin Seniw	Reply Requested by: 09/11/2024	Issue Date: 9/6/24

RFI DESCRIPTION (Indicate origin of RFI, and summarize the question or type of information required):

large icemaker in medical supplies only comes to be hard wired but electrical drwgs show it is a plug in.. ~~Please provide direction for electrician to hard wire it on tandem~~

REFERENCES (List relevant Drawings or Specification sections and paragraphs):

SENDER'S RECOMMENDATION (All RFIs must include a contractor's recommended solution to each condition, including a statement of cost or schedule of impact if applicable. The contractor may be back-charged by the Town of Stoughton for designer's review time for any RFI submitted without a sender's recommended solution or where response is evident in Drawings.)

DESIGNER'S RESPONSE:

Refer to Engineers response on following page.

BY:

Kevin Seniw

Digitally signed by Kevin Seniw
Contact Info:
kseniw@doreandwhittier.com
Date: 2024.09.11

DATE:

COPIES TO:

GGD Consulting Engineers, Inc.

REQUEST FOR INFORMATION - RFI

M#90446
J#894 109 01.00

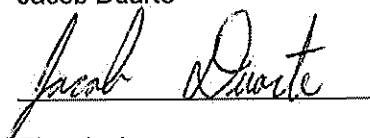
DATE: September 10, 2024
TO: Kevin Senlw
Dore + Whittler
FROM: Jacob Duarte

DEPT: Electrical
PROJECT: Stoughton Fire Station No. 1
Stoughton, MA
SUBJECT: RFI #155: Icemaker Hardwire

Question:

Large icemaker in Medical Supplies only comes to be hard wired, but Electrical Drawings show Is it a plug in. ~~Please provide direction for electrician to hard wire it on T & M.~~

Response:

Electrical Contractor to remove duplex receptable and utilize back box for splice box. Electrical Contractor to provide a whip connection to a thermal rated motor switch for unit disconnecting means.

JD:kc

Enc.

Cc: Heather Gratton, Dore + Whittler
Glen Gollrad, Dore + Whitter

September 20, 2024

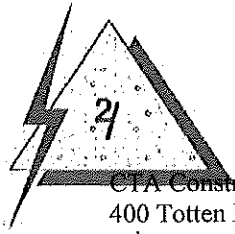

CTA Construction Managers
400 Totten Pond Road
2nd Floor
Waltham, MA 02451
Attn: Terry Vieux tvieux@ctaconstruction.com
Paula Martin pmartin@ctaconstruction.com
Tel: 781-786-6629

RE: Stoughton Fire Station 400 Prospect Steet Stoughton, MA 02072 Change Order Proposal:
#2316-127

To Whom it May Concern,

COP #2316-127 – 9/10/24 T&M in the amount of \$358.84.

DESCRIPTION	UNIT	UNIT	LABOR	LABOR	
MATERIAL	QTY	COST	EXT	EXT	
T&M on 9/10/24	1		\$0.00	3	3
3/4 Flex 90 Connector	2	4	\$8.00		0
White Stainless Blank	1	4.75	\$4.75		0
#12 THHN	20	0.26	\$5.20		0
3/8 Flex	5	2	\$10.00		0
			\$0.00		0
Subtotal			\$27.95		3.00
LABOR					
Electrician	3.00	\$76.48	\$229.44		
30% Insurance and Tax			\$68.83		
Total Labor			\$298.27		
Total Material			\$27.95		
Subtotal Labor and Material			\$326.22		
10% Overhead and Profit			\$32.62		
TOTAL CHANGE ORDER AMOUNT			\$358.84		

If you have any questions or concerns, please call our office.

Thank you,
Brad Kelloway, Project Manager

J
U
P
I
T
E
R
E
L
E
C
T
R
I
C
I
N
C.

JUPITER ELECTRIC, INC.
 142 B Lafayette Road
 Salisbury, Ma. 01952
 Phone:(978)499-7776
 Fax:(978)499-3838

Work Order

Work order #: _____ Date: 9/10/24

To: Bob Rice (Pomroy) Job: Slaughter Fire

Work Performed:
 2 Kitchen Hood Fan Fire Suppression Test
 hard wire ice machine

MATERIAL

Quantity	Description
2	3/4" 90 conn
1	white blank stainless plate
20'	#12 THHN
5'	3/8" Flex
Labor Steve B 7:30 - 10:30	
3 hrs	

TIME

Hours	Description	Total

Signature:  Title: OPH Date: 9/13/24



CTA Construction Managers
 400 Totten Pond Road
 Waltham, 02451
 Phone: (781) 786-6600

Project: 2023-01 - Stoughton Fire Station No.01
 400 Prospect Street
 Stoughton, 02072

Prime Contract Potential Change Order #088: CE #164 - CCD 10, rfi 147- add concrete pad

TO:	Town of Stoughton 10 Pearl St Stoughton Massachusetts, 02072	FROM:	CTA Construction Managers, LLC 400 Totten Pond Road, 2nd Floor Waltham Massachusetts, 02451
PCO NUMBER/REVISION:	088 / 0	CONTRACT:	1 - Stoughton Fire Station No 1
REQUEST RECEIVED FROM:		CREATED BY:	Jo-Ann Darrigo (CTA Construction Managers, LLC)
STATUS:	Pending - In Review	CREATED DATE:	10/21 /2024
REFERENCE:		PRIME CONTRACT CHANGE ORDER:	None
FIELD CHANGE:	No		
LOCATION:		ACCOUNTING METHOD:	Amount Based
SCHEDULE IMPACT:		PAID IN FULL:	No
		TOTAL AMOUNT:	\$1,283.17

POTENTIAL CHANGE ORDER TITLE: CE #164 - CCD 10, rfi 147- add concrete pad

CHANGE REASON: Client Request

POTENTIAL CHANGE ORDER DESCRIPTION: *(The Contract Is Changed As Follows)*
CE #164 - CCD 10, rfi 147- add concrete pad

*CTA reserves its rights to additional time and direct and indirect costs associated with this change order. CTA does not waive its rights to an additional extension of time or to recover additional costs by signing this change order. The Awarding Authority, in executing this change order, agrees that CTA has properly reserved its rights for additional time and compensation.

ATTACHMENTS:

#	Cost Code	Description	Type	Amount
1	01-000 - Purpose	CCD 11-materials	CTA Direct	\$ 396.59
2	01-000 - Purpose	CCD 11- labor	CTA Direct	\$ 769.93
Subtotal:				\$1,166.52
CTA Direct: 10.00% Applies to CTA Direct.				\$ 116.65
CTA Sub: 5.00% Applies to CTA Sub .				\$ 0.00
Filed Sub: 5.00% Applies to Filed Sub Bidder .				\$ 0.00
CTA Bonds & Insurance: 0.00% Applies to Filed Sub Bidder , CTA Sub , and CTA Direct.				\$ 0.00
Grand Total:				\$1,283.17



PCO #088

CTA Construction Managers
 400 Totten Pond Road
 Waltham, 02451
 Phone: (781) 786-6600

Project: 2023-01 - Stoughton Fire Station No.01
 400 Prospect Street
 Stoughton, 02072

Prime Contract Potential Change Order #088: CE #164 - CCD 10, rfi 147- add concrete pad

TO:	Town of Stoughton 10 Pearl St Stoughton Massachusetts, 02072	FROM:	CTA Construction Managers, LLC 400 Totten Pond Road, 2nd Floor Waltham Massachusetts, 02451
PCO NUMBER/REVISION:	088 / 0	CONTRACT:	1 - Stoughton Fire Station No 1
REQUEST RECEIVED FROM:		CREATED BY:	Jo-Ann Darrigo (CTA Construction Managers, LLC)
STATUS:	Pending - In Review	CREATED DATE:	10/21 /2024
REFERENCE:		PRIME CONTRACT CHANGE ORDER:	None
FIELD CHANGE:	No		
LOCATION:		ACCOUNTING METHOD:	Amount Based
SCHEDULE IMPACT:		PAID IN FULL:	No
		TOTAL AMOUNT:	\$2,827.56

POTENTIAL CHANGE ORDER TITLE: CE #164 - CCD 10, rfi 147- add concrete pad

CHANGE REASON: Client Request

POTENTIAL CHANGE ORDER DESCRIPTION: *(The Contract Is Changed As Follows)*
CE #164 - CCD 10, rfi 147- add concrete pad

*CTA reserves its rights to additional time and direct and indirect costs associated with this change order. CTA does not waive its rights to an additional extension of time or to recover additional costs by signing this change order. The Awarding Authority, in executing this change order, agrees that CTA has properly reserved its rights for additional time and compensation.

ATTACHMENTS:

#	Cost Code	Description	Type	Amount
1	01-000 - Purpose	CCD 11-materials	CTA Direct	\$ 396.69
2	01-000 - Purpose	CCD 11- labor	CTA Direct	\$ 2,173.92
Subtotal:				\$2,570.51
CTA Direct: 10.00% Applies to CTA Direct.				\$ 257.05
CTA Sub: 5.00% Applies to CTA Sub .				\$ 0.00
Filed Sub: 5.00% Applies to Filed Sub Bidder .				\$ 0.00
CTA Bonds & Insurance: 0.00% Applies to Filed Sub Bidder , CTA Sub , and CTA Direct.				\$ 0.00
Grand Total:				\$2,827.56

WHITE CAP®

White Cap, L.P.
PO Box 4944
Orlando, FL 32802-4944

BRANCH ADDRESS
111 - STOUGHTON

(781) 436-7119
45 MAPLE ST
STOUGHTON MA 02072
NORFOLK

INVOICE

INVOICE NUMBER
50028455197
INVOICE DATE
09/23/2024
CUSTOMER PO NUMBER

TO VIEW AND PAY ONLINE GO TO:
http://whitecap.billtrust.com
ENROLLMENT TOKEN:
FMX QFW BTQ

MAKE CHECKS PAYABLE TO:
White Cap, L.P. P.O. Box 4852 ORLANDO, FL 32802-4852

ACCOUNT # 10000127607

TERRITORY:
SHIP TO: 10004341839

CTA CONSTRUCTION CO INC
400 TOTTEN POND ROAD
WALTHAM MA 02451

STOUGHTON FIRE STATION
400 PROSPECT STREET
STOUGHTON MA 02072

ORDER DATE	ORDER NO.	ORDERED BY	ACCOUNT MANAGER	TAKEN BY				
09/23/2024	61863720	LEO GALLANT	STEVENS, KEN	ROBINSON, AMARION				
BRANCH	ACCT JOB NO.	TERMS	SHIP VIA / ROUTING	CUSTOMER JOB NO.				
111	10004341839	NET 30 DAYS	0. WILL CALL	STOUGHTON FIRE				
LINE	PART NUMBER	DESCRIPTION	QTY ORD	UNIT PRICE	QTY BKO	QTY SHP	EXTENDED PRICE	TAX AMT
0	HDRDESC	***** DELIVERY TAG#: 31460098 *****	1	0	0	1	0.00	
1	44380HSCM	80LB BAG 5000PSI HIGH STRENGTH CONCRETE MIX VITACRETE VITA CRETE	16	11.64 BAG	0	16	186.24	0.00
2	43541060	#4 GR60 1/2"X10' REBAR SOLD/PC	4	7.59 EA	0	4	30.36	0.00
3	444BR12635	6 CUBIC FOOT STEEL TRAY CONTRACTOR WHEELBARROW WITH SOLID FLAT FREE ALL TERRAIN TIRE BRIGADE	1	179.99 EA	0	1	179.99	11.25

The White Cap Family of Brands includes All-Tex Waterproofing Solutions, Harmac, Kenseal, Marvel Building & Masonry Supply, MASONPRO, Williams Equipment & Supply, Valley Supply Co, and Diamond Tool. Learn more at About.WhiteCap.com

Pay your invoices online by visiting: <https://whitecap.billtrust.com>

Sales Tax Exemption Questions or Certificates: TaxExemptCredit@whitecap.com

THESE ITEMS ARE CONTROLLED BY THE U.S. GOVERNMENT AND AUTHORIZED FOR EXPORT ONLY TO THE COUNTRY OF ULTIMATE DESTINATION FOR USE BY THE ULTIMATE CONSIGNEE OR END-USER(S) HEREIN IDENTIFIED. THEY MAY NOT BE RESOLD, TRANSFERRED OR OTHERWISE DISPOSED OF TO ANY OTHER COUNTRY OR ANY PERSON OTHER THAN THE AUTHORIZED ULTIMATE CONSIGNEE OR END-USER(S), EITHER IN THEIR ORIGINAL FORM OR AFTER BEING INCORPORATED INTO OTHER ITEMS, WITHOUT FIRST OBTAINING APPROVAL FROM THE U.S. GOVERNMENT OR AS OTHERWISE AUTHORIZED BY U.S. LAW AND REGULATIONS.

For questions regarding this invoice please call (866) 434-9192

NO REFUNDS OR EXCHANGES ON NON STOCK MERCHANDISE
Visit <https://www.whitecap.com/terms/terms-conditions-of-sale-terms> to view complete terms and conditions.

TOTAL GROSS	396.59
TOTAL TAX	11.25
TOTAL SHIPPING AND HANDLING	0.00
TOTAL INVOICE	407.84

RECEIVED BY: LEO GALLANT

SIGNATURE COPY ON FILE

JNB CONSTRUCTION INC

stoughton

Labor for Week Ending: 9 27 2024

	Regular	Overtime	Total	Rate	Wages
kelly				\$40.00	
nathan				\$40.00	
willie	24		24	\$64.70	\$1,552.80
suarez				\$64.70	
TOTAL	24	0	24		\$1,552.80
			8		
				40%	621.12
					<u>621.12</u>
					TOTAL: \$2,173.92

769.93

Company: JNB Construction, Inc.
 Employee: W. V. L. C.
 Week Ending: 9-27-24

Weekly Time Summary
 Project Name

Day	Project Name	Work Description	Cost Code	Regular Time	General Cleaning	Fireproofing	Winter Weather	Protection and Safety	Punchlist	Apply	Stucco	Total Hours	DETAILED DESCRIPTION OF WORK AND METHODS (TO BE COMPLETED BY THE SUPERINTENDENT)	SUPER SIGNATURE
Sunday														
Monday	Stoughton FS											8	<p>Put out Alents and learn Form up Drill Redbor and Power/mix concrete sidewalk</p>	[Signature]
Tuesday	Stoughton FS			2								8	<p>Strip Formwork Mortise 4 later sets @ slides office Application - Setop - Some Clean Safety / cooling - Punch Items Clean all sidewalks and door STOPS</p>	[Signature]
Wednesday	Stoughton FS			8								8	<p>Office Speed CR metal mix time</p>	[Signature]
Thursday														
Friday														
Saturday														
WEEKLY TOTAL:														



PCO #089

CTA Construction Managers
 400 Totten Pond Road
 Waltham, 02451
 Phone: (781) 786-6600

Project: 2023-01 - Stoughton Fire Station No.01
 400 Prospect Street
 Stoughton, 02072

Prime Contract Potential Change Order #089: CE #118 - relocate vrf in kitchen

TO:	Town of Stoughton 10 Pearl St Stoughton Massachusetts, 02072	FROM:	CTA Construction Managers, LLC 400 Totten Pond Road, 2nd Floor Waltham Massachusetts, 02451
PCO NUMBER/REVISION:	089 / 0	CONTRACT:	1 - Stoughton Fire Station No 1
REQUEST RECEIVED FROM:		CREATED BY:	Jo-Ann Darrigo (CTA Construction Managers, LLC)
STATUS:	Pending - In Review	CREATED DATE:	10/21 /2024
REFERENCE:		PRIME CONTRACT CHANGE ORDER:	None
FIELD CHANGE:	No		
LOCATION:		ACCOUNTING METHOD:	Amount Based
SCHEDULE IMPACT:		PAID IN FULL:	No
		TOTAL AMOUNT:	\$1,448.86

POTENTIAL CHANGE ORDER TITLE: CE #118 - relocate vrf in kitchen

CHANGE REASON: Client Request

POTENTIAL CHANGE ORDER DESCRIPTION: *(The Contract Is Changed As Follows)*

CE #118 - relocate vrf in kitchen
 relocate vrf in kitchen to be located above ACT

*CTA reserves its rights to additional time and direct and indirect costs associated with this change order. CTA does not waive its rights to an additional extension of time or to recover additional costs by signing this change order. The Awarding Authority, in executing this change order, agrees that CTA has properly reserved its rights for additional time and compensation.

ATTACHMENTS:

PCO #8 Remove Unit Piping + Reinstall TM.pdf

#	Cost Code	Description	Type	Amount
1	15-600 - Refrigeration Equipment	relocate vrf in kitchen	Filed Sub Bidder	\$ 1,379.87
Subtotal:				\$1,379.87
CTA Direct: 10.00% Applies to CTA Direct.				\$ 0.00
CTA Sub: 5.00% Applies to CTA Sub .				\$ 0.00
Filed Sub: 5.00% Applies to Filed Sub Bidder .				\$ 68.99
CTA Bonds & Insurance: 0.00% Applies to Filed Sub Bidder , CTA Sub , and CTA Direct.				\$ 0.00
Grand Total:				\$1,448.86



CAM H.V.A.C. & Construction, Inc.

116 Lydia Ann Road
Smithfield, RI 02917
(401) 232-7230
(401) 232-7290 Fax

CTA Construction Managers
400 Totten Pond Road
Waltham MA, 02451
Phone: (781) 786-6600

Date: October 9, 2024
Job Title: Stoughton Fire Station #1
Created by: Dennis Lutskiy - APM
Attention: Terry Vieux- Project Manager
tvieux@ctaconstruction.com
Sent Via: E-Mail

CAM HVAC CHANGE PROPOSAL # 8

DESCRIPTION OF CHANGE: PCO #8 Remove Unit & Piping + Reinstall T&M

MATERIAL COST CHANGES

Material Pricing	1 LOT	X	142.37		\$142.37
Misc Hardware	1 LOT	X	50.00		\$50.00
	1 LOT	X	0.00		\$0.00
	MATERIAL SUBTOTAL				<u>\$192.37</u>
O&P	15%	X	192.37		<u>\$28.86</u>
<u>MATERIAL COST TOTALS</u>					<u>\$221.23</u>

LABOR COST CHANGES

Total Labor is 8 Hours See T&M For Breakdown	8 HRS	X	101.28	PF	\$810.24
	0 HRS	X	104.04	SM	\$0.00
	0 HRS	X	64.65	Laborer	<u>\$0.00</u>
	SUBTOTAL				<u>\$810.24</u>
Burden	30%	X	810.24		<u>\$243.07</u>
	LABOR SUBTOTAL				<u>\$1,053.31</u>
O&P	10%	X	1,053.31		<u>\$105.33</u>
<u>CAM LABOR COST TOTALS</u>					<u>\$1,158.64</u>

SUBCONTRACTORS' COST CHANGES

Balancing Add	1 LOT	X	0.00		\$0.00
Control Add	1 LOT	X	0.00		\$0.00
Insulation Add	1 LOT	X	0.00		\$0.00
	1 LOT	X	0.00		<u>\$0.00</u>
	SUBTOTAL				<u>\$0.00</u>
O&P	10%	X	0.00		<u>\$0.00</u>
<u>SUBCONTRACTORS' COST TOTALS</u>					<u>\$0.00</u>

	SUBTOTAL FOR PROPOSAL # 8				<u>\$1,379.87</u>
BOND PREMIUM		0.000% X	1,379.87		\$0.00
	TOTAL FOR PROPOSAL # 8			ADD	<u>\$1,379.87</u>

GENERAL NOTE(S):

- All work is priced to be performed during a regular 8 hour work day. Holiday and overtime rates do not apply and are subject to additional charges if required.
- This change order should carry a time extension of TBD work days.



FEL-TAUNTON #985
 300 CHARLES F COLTON RD
 TAUNTON, MA 02780-7914

Phone: 508-844-2512
 Fax: 508-528-7810

Deliver To:	
From:	Marcell Cooper-teleau
Comments:	

07:14:27 OCT 09 2024

Page 1 of 1

FERGUSON ENTERPRISES LLC #1196

Price Quotation

Phone: 508-844-2512
 Fax: 508-528-7810

Bld No: B266767
Bid Date: 10/09/24
Quoted By: MCT

Cust Phone: 401-232-7230
Terms: NET 10TH PROX

Customer: CAM HVAC & CONSTRUCTION IN
 116 LYDIA ANN ROAD
 SMITHFIELD, RI 02917

Ship To: CAM HVAC & CONSTRUCTION IN
 116 LYDIA ANN ROAD
 SMITHFIELD, RI 02917

Cust PO#:

Job Name: STOUGHTON

Item	Description	Quantity	Net Price	UM	Total
GST7882B12Z2S1	1-5/8X1-5/8X10 GALV H/SL BB STRUT	10	869.999	C	87.00
GATRCU	3/8X6 Z/PLT ATR	24	0.703	FT	16.87
LCCAPB10	1/4 X 10 L HARD C&C COP TUBE 3/8 OD	10	154.030	C	15.40
LCCAPC10	3/8 X 10 L HARD C&C COP TUBE 1/2 OD	10	231.045	C	23.10

Net Total: \$142.37
Tax: \$0.00
Freight: \$0.00
Total: \$142.37

Quoted prices are based upon receipt of the total quantity for immediate shipment (48 hours). SHIPMENTS BEYOND 48 HOURS SHALL BE AT THE PRICE IN EFFECT AT TIME OF SHIPMENT UNLESS NOTED OTHERWISE. QUOTES FOR PRODUCTS SHIPPED FOR RESALE ARE NOT FIRM UNLESS NOTED OTHERWISE.

CONTRACTOR CUSTOMERS: IF YOU HAVE DBE/MBE/WBE/VBE/SDVBE/SBE GOOD FAITH EFFORTS DIVERSITY GOALS/ REQUIREMENTS ON A FEDERAL, STATE, LOCAL GOVERNMENT, PRIVATE SECTOR PROJECT, PLEASE CONTACT YOUR BRANCH SALES REPRESENTATIVE IMMEDIATELY PRIOR TO RECEIVING A QUOTE/ORDER.

Seller not responsible for delays, lack of product or increase of pricing due to causes beyond our control, and/or based upon Local, State and Federal laws governing type of products that can be sold or put into commerce. This Quote is offered contingent upon the Buyer's acceptance of Seller's terms and conditions, which are incorporated by reference and found either following this document, or on the web at <https://www.ferguson.com/content/website-info/terms-of-sale>
 Govt Buyers: All items are open market unless noted otherwise.

LEAD LAW WARNING: It is illegal to install products that are not "lead free" in accordance with US Federal or other applicable law in potable water systems anticipated for human consumption. Products with *NP in the description are NOT lead free and can only be installed in non-potable applications. Buyer is solely responsible for product selection.
 Buyer shall accept delivery of products within 60 days of Seller receiving the products at Seller's warehouse. If Buyer causes or requests a delay in delivery of the products, Buyer may be subject to storage fees and additional costs caused by such delay. Seller reserves the right to requote the products and reschedule the delivery date, subject to manufacturer's lead times and price increases, if Buyer is unable to accept delivery within 60 days.

HOW ARE WE DOING? WE WANT YOUR FEEDBACK!

Scan the QR code or use the link below to complete a survey about your bids:

<https://survey.medallia.com/?bidsorder&fc=1196&on=268774>





Camp P. W. C. & Construction Inc.
 116 LYDIA ANN RD.
 (401) 232-7230
 SMITHFIELD, RI 02917
 FAX (401) 232-7290

JOB NAME		WORK AUTHORIZATION		DATE	
ADDRESS		JOB NUMBER		CHECK ONE:	
CITY & STATE		PAGE OF		<input type="checkbox"/> TIME & MATERIAL	
DESCRIPTION OF WORK		COD #		<input type="checkbox"/> SERVICE DIVISION WORK	
2 Hours Remove old concrete base		04260		<input type="checkbox"/> OTHER (PLEASE SPECIFY)	
2 Hours Re-heat units before concrete					
3 Hours					

PRE-AUTHORIZATION:
 AUTHORIZED SIGNATURE: X
 YOU ARE HEREBY AUTHORIZED TO PERFORM THE ABOVE ADDITIONAL WORK UNDER THE SAME CONDITIONS AS SPECIFIED IN THE ORIGINAL CONTRACT PROPOSAL UNLESS OTHERWISE STIPULATED

QUANTITY	MATERIAL	QUANTITY	TIME AND LABOR RECORD						QUANTITY	MATERIAL
			IN	OUT	IN	OUT	HOURS	WORKER		
1	Concrete									
1	Concrete									
1	Concrete									
1	Concrete									
1	Concrete									
1	Concrete									
1	Concrete									
1	Concrete									
1	Concrete									

WORKER	DATE	IN	OUT	IN	OUT	HOURS	WORKER	TIME AND LABOR RECORD										
								IN	OUT	IN	OUT	HOURS	WORKER					
John C. Desires	4-12-24					1	John C. Desires											

POST WORK AUTHORIZED SIGNATURE: X
 (THE LABOR AND MATERIALS LISTED ABOVE ARE ACCURATE AND THE WORK WAS COMPLETED SATISFACTORILY)

R. J. [Signature]
 4/16/24



Cambridge C. & Construction Inc.

116 LYDIA ANN RD.
(401) 232-7230

SMITHFIELD, RI 02917
FAX (401) 232-7290

WORK AUTHORIZATION

JOB NAME		JOB NUMBER		DATE	9 / 10 / 2011
ADDRESS		PAGE	OF	CHECK ONE:	
CITY & STATE				<input type="checkbox"/> TIME & MATERIAL	
<i>2 hours concrete wall for...</i>		DESCRIPTION OF WORK		<input type="checkbox"/> SERVICE DIVISION WORK	
				<input type="checkbox"/> OTHER (PLEASE SPECIFY)	
COD #					

PRE-AUTHORIZATION:
AUTHORIZED SIGNATURE X

DATE: / /

04260

YOU ARE HEREBY AUTHORIZED TO PERFORM THE ABOVE ADDITIONAL WORK UNDER THE SAME CONDITIONS AS SPECIFIED IN THE ORIGINAL CONTRACT PROPOSAL UNLESS OTHERWISE STIPULATED

MATERIAL AND LABOR BREAKDOWN										
QUANTITY	MATERIAL	QUANTITY	MATERIAL	DATE	IN	OUT	IN	OUT	HOURS	

TIME AND LABOR RECORD

WORKER	DATE	IN	OUT	IN	OUT	HOURS	WORKER	DATE	IN	OUT	IN	OUT	HOURS

POST WORK
AUTHORIZED SIGNATURE X

THE LABOR AND MATERIALS LISTED ABOVE ARE ACCURATE AND THE WORK WAS COMPLETED SATISFACTORILY.



CTA Construction Managers
400 Totten Pond Road
Waltham, 02451
Phone: (781) 786-6600

Project: 2023-01 - Stoughton Fire Station No.01
400 Prospect Street
Stoughton, 02072

Prime Contract Potential Change Order #084: CE #163 - rfi 154 add boiler emerg switches per inspector

Table with 2 columns: Field Name and Value. Fields include TO, FROM, PCO NUMBER/REVISION, CONTRACT, REQUEST RECEIVED FROM, CREATED BY, STATUS, CREATED DATE, REFERENCE, PRIME CONTRACT CHANGE ORDER, FIELD CHANGE, LOCATION, ACCOUNTING METHOD, SCHEDULE IMPACT, PAID IN FULL, and TOTAL AMOUNT.

POTENTIAL CHANGE ORDER TITLE: CE #163 - rfi 154 add boiler emerg switches per inspector

CHANGE REASON: Client Request

POTENTIAL CHANGE ORDER DESCRIPTION: (The Contract Is Changed As Follows)

CE #163 - rfi 154 add boiler emerg switches per inspector

rfi 154- boiler inspector requested additional emerg. switches at exterior door, so one existing pair were relocated.

*CTA reserves its rights to additional time and direct and indirect costs associated with this change order. CTA does not waive its rights to an additional extension of time or to recover additional costs by signing this change order. The Awarding Authority, in executing this change order, agrees that CTA has properly reserved its rights for additional time and compensation.

ATTACHMENTS:

2316-131 9.18.24 TM- boiler switch relocation.pdf

Table with 4 columns: #, Cost Code, Description, Type, and Amount. It lists a single line item for 'relocate switches' and includes a detailed breakdown of costs and percentages for CTA Direct, CTA Sub, Filed Sub, and CTA Bonds & Insurance, ending with a Grand Total of \$679.09.

September 20, 2024

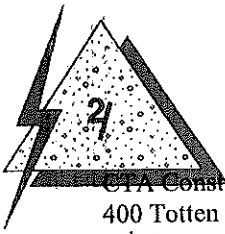

CTA Construction Managers
 400 Totten Pond Road
 2nd Floor
 Waltham, MA 02451
 Attn: Terry Vieux tvieux@ctaconstruction.com
 Paula Martin pmartin@ctaconstruction.com
 Tel: 781-786-6629

J
U
P
I
T
E
R
E
L
E
C
T
R
I
C
I
N
C.

RE: **Stoughton Fire Station 400 Prospect Steet Stoughton, MA 02072 Change Order Proposal: #2316-131**

To Whom it May Concern,

COP #2316-131 – 9/18/24 T&M in the amount of \$646.75.

DESCRIPTION	UNIT	UNIT COST	UNIT EXT	LABOR HOURS	LABOR EXT
T&M on 9/18/24	1		\$0.00	4.5	4.5
4sq Boxes	2	3.15	\$6.30		0
Handy Box Extension Ring	1	3.85	\$3.85		0
Handy Box Blank Plate	1	1	\$1.00		0
Single Gang Blank Cover	1	1.2	\$1.20		0
1/2 Flex	30	0.75	\$22.50		0
3/4 to 1/2 Flex Change Over	2	3.5	\$7.00		0
3/4 EMT	10	1	\$10.00		0
3/4 EMT Conn.	2	4.75	\$9.50		0
3/4 Supports	2	1	\$2.00		0
Plastic Anchors	1	10	\$10.00		0
1" Ten's	1	10	\$10.00		0
#12 THHN	220	0.26	\$57.20		0
			\$0.00		0
			\$0.00		0
Subtotal			\$140.55		4.50
LABOR					
Electrician	4.50	\$76.48	\$344.16		
30% Insurance and Tax			\$103.25		
Total Labor			\$447.41		
Total Material			\$140.55		
Subtotal Labor and Material			\$587.96		
10% Overhead and Profit			\$58.80		
TOTAL CHANGE ORDER AMOUNT			\$646.75		

If you have any questions or concerns, please call our office.

Thank you,

Brad Kelloway, Project Manager

142 B Lafayette Road
 Salisbury, Ma. 01952
 Phone:(978)499-7776
 Fax:(978)499-3838

Work Order

Work order #:

Date:

9/18/24

To: Bob Reie (ParRay)

Job:

Stoughton Fire

Work Performed:

move switches for Boiler shut offs to Exterior Door wall.

MATERIAL

Quantity	Description
2	4" Square Boxes
2	Single gang Flat Plaster Rings
1	Hand box extension Ring
1	Hand box Blank Plate
1	Single Gang Blank Plate white
30'	2 1/2" Flex
2	3/4" EMT to 1/2" Flex Changeovers
10'	3/4" EMT
2	3/4" EMT conn
2	3/4" 12P clips
10	Plastic Anchors
10	1" x 10 Screws
220'	#12 THHN

Labour 4.5 11-3:30

Steve Burke

T & M under Protest !!

WORK COMPLETE SIGNATURE DOES NOT GUARANTEE PAYMENT

TIME

Hours	Description	Total

Signature:



Title:

OPM

Date: 9-19-24